

■ Abstract

The history of sound recording started with the "Phonograph," the machine invented by Thomas Edison in the USA in 1877. Following that invention, Oberlin Smith, an American engineer, announced his idea for magnetic recording in 1888. Ten years later, Valdemar Poulsen, a Danish telephone engineer, invented the world's first magnetic recorder, called the "Telegraphone," in 1898. The Telegraphone used thin metal wire as the recording material. Though wire recorders like the Telegraphone did not become popular, research on magnetic recording continued all over the world, and a new type of recorder that used tape coated with magnetic powder instead of metal wire as the recording material was invented in the 1920's. The real archetype of the modern tape recorder, the "Magnetophone," which was developed in Germany in the mid-1930's, was based on this recorder. After World War II, the USA conducted extensive research on the technology of the requisitioned Magnetophone and subsequently developed a modern professional tape recorder. Since the functionality of this tape recorder was superior to that of the conventional disc recorder, several broadcast stations immediately introduced new machines to their radio broadcasting operations. The tape recorder was soon introduced to the consumer market also, which led to a very rapid increase in the number of machines produced. In Japan, Tokyo Tsushin Kogyo, which eventually changed its name to Sony, started investigating magnetic recording technology after the end of the war and soon developed their original magnetic tape and recorder. In 1950 they released the first Japanese tape recorder.

In the 1960's several cartridge-type tape recorders were developed to meet the requirements of car-stereo devices, and finally, the compact cassette system was introduced. Japanese manufacturers contributed to improving the basic recording performance of compact cassette recorders and to expanding the variety of available products, especially small-sized tape recorders. As a result, they attained a large market share in the worldwide tape recorder market. In 1979 the "Walkman," a portable compact cassette player, was introduced to the market, and in a very short period it became very popular all over the world. The product concept of the Walkman was well accepted, and it changed the style of audio listening dramatically.

In this report I briefly describe the history of sound recording, particularly the progress and relation of magnetic recording technologies in the compact cassette system. I also describe the product concept and downsizing technologies of the Walkman. In the last section, I explain the development of digital audio tape (DAT), an advanced tape recording system that led to the rise of digital audio technology.

Japanese audio manufacturers joined the tape recorder market relatively soon after the end of World War II. Around 1970 the technical capabilities of device manufacturers increased rapidly, and many superior devices such as precision mechanical components and high-performance electrical devices became available on the domestic market. The synergy effect between product design and device technologies improved the competitiveness of the final products, and Japanese audio manufacturers achieved success in the compact cassette tape recorder market. They changed the style of listening and the audio product itself with their introduction of the stereo-headphone "Walkman" in 1979. They ultimately succeeded in getting a huge market share of the worldwide audio market.

Many people have recently been enjoying listening to music supplied in a digitally compressed format with small portable devices and headphones. However, it is hoped that the Japanese audio industry will develop a revolutionary new product or service for a more comfortable listening experience with even better sound.

■ Profile

Masanori Kimizuka

**Chief Survey Officer, Center of the History of Japanese Industrial Technology,
National Museum of Nature and Science, Tokyo**

March 1973: Graduated from the Department of Mechanical Engineering, Osaka University
April 1973: Started working at Sony Corporation
Involved in the design and development of audio equipment and storage equipment
February 2006: Representative Director of Start Lab, Inc.
December 2011: Left Start Lab
Left Sony Corporation
Present: Part-time lecturer at Tokyo University of the Arts
Director of Japan Audio Society

■ Contents

1. Introduction	185
2. Recording Sound	187
3. Invention of Magnetic Recording	189
4. Post-war Tape Recorders	197
5. Development of Domestically-Produced Tape Recorders	206
6. Emergence of Cartridge-Type Tape Recorders	215
7. Structure and Performance of Compact Cassette-Type Tape Recorders	224
8. Magnetic Tape in Compact Cassettes	227
9. Advances in Magnetic Heads for Compact Cassettes	229
10. Development of Three-Head Compact Cassettes	234
11. Noise Reduction Systems	238
12. Advances in Driving Motors	244
13. Towards the "Headphone Stereo"	251
14. Invention of Digital Audio Tape Recorders (DAT)	258
15. Conclusion	269
Tape Recorder System Diagrams	271
Chronological Table	272
List of Tape Recorders	273

1 | Introduction

Many thousands of years ago, people painted various images on rock surfaces. The vivid animal depictions in the famous Cave of Altamira, thought to have been painted as a ritual to the gods, are still-image records left by the people of the time. Since ancient times, people have dreamt of recording sound in the same way as pictures; however, they lacked the means to record it, other than passing it down through the oral traditions of story and song. When writing was invented, people could record their voices through this innovative means of “recording words using letters”. With regard to music, however, capturing the sound itself held more significance than the recording of mere words. People devised notation systems as a means to record the sounds of music and a number of civilisations had their own notations and symbols for this purpose. However, this “sheet music” was still an indirect means of recording music. The recording of sound itself remained a dream.

Around the mid-19th century, Frenchman Édouard-Léon Scott de Martinville devised a machine that could record the changes in a sound waveform against a time axis, based on the idea that sound is transmitted as a wave. Although Scott de Martinville’s machine could record sound waveforms, it could not reproduce the recorded waveform as sound. In 1877, around 20 years later, American inventor Thomas Edison invented the “phonograph”, a machine that could reproduce sound by producing a vibration from a sound waveform recorded on a brass cylinder wrapped in tin foil. For the first time in human history, a machine could record and reproduce sound. The more advanced gramophone record was a later improvement to the device. This advancement meant that the device could be developed not only as a sound recorder, but also as a household music player through these records. As radio broadcasting gained popularity, disc recorders became vital pieces of equipment for recording and playing back sound, used by many broadcasting offices until the end of the Second World War. While records improved in quality, increased in length and progressed to stereo, the principle of sound recording remained the same: mechanically recording or etching raw sound waveforms onto media.

Telecommunications technology developed rapidly in the 19th century and telegraphy became increasingly more practical. In 1876, American inventor Graham Bell invented the telephone, which could transmit sound itself. Based on the idea that telephonic sound is converted into electricity and could thus be recorded in the form of magnetic changes, American Oberlin Smith published the world’s first article on the concept of magnetic recording. In 1898, inspired by this concept, Danish engineer Valdemar Poulsen used steel wire to build the “Telegraphone” wire recorder, the world’s first

practical magnetic recording machine.

Just before the Second World War, a magnetic recording machine was proposed in Germany, which replaced the steel wire with tape, making it easier to use. This was the birth of the prototype tape recorder. While the war prevented countries from exchanging magnetic tape recording technology, research progressed in Germany and the technology continued to improve. By the end of the war, the tape recorder was complete, equipped with advanced technology such as AC bias and stereo recording. After the war, the Allies carried out a detailed investigation of all German technology related to magnetic recording; this technology then became widely used in the development of tape recorders in the United States. Ampex, a small, newly-founded company, took on the challenge of developing the tape recorder in the United States; before long, it was an industry-leading corporation, making major contributions to the technical advancement and development of the tape recorder. With Europe lagging a little behind the times, Studer, a small Swiss company, began to develop the tape recorder there. It developed superior models, from business machines to luxury consumer products, and became the leader of the industry in Europe. In Japan, Tokyo Tsushin Kogyo (later Sony), founded not long after the end of the war, persevered in researching magnetic recording, believing in its potential. In 1950, the company completed the first domestically-produced tape recorder in impoverished post-war Japan. After the war, tape recorder technology and its potential star qualities went public. Venture companies in Japan, Europe and the United States alike took on the tape recorder challenge, and a number of interesting designs emerged.

While tape recorders first gained popularity for business use, companies soon began to develop models for general use as well, and these machines quickly gained popularity for household use. In the United States, they became the popular choice of audio equipment for entertainment with the sale of music tapes, which had converted to stereo much faster than records had. Companies began to focus on easy-to-use cartridge-style tape recorders, with car stereos as a possible application. In the early 1960s, companies began to propose multiple-cartridge systems. A compact cassette proposed by the Dutch company Philips established itself as the effective global standard with a royalty free patent licence policy. By this time, Japanese companies were becoming more confident in their development and design of AV equipment. Parts manufacturers, who supplied electronic components and equipment parts, began to improve their technological capabilities, developing better quality and more

advanced parts and actively working to incorporate them into their designs. Like the compact cassette tape recorder, technological developments were standardised, high in performance and packed with features. This work required perseverance and meticulous attention to detail, but Japanese companies were well suited to this and ended up leading the compact cassette tape recorder industry. At the same time, other audio equipment also began to be sought after around the world. The 1970s and 1980s ushered in a golden age for the Japanese audio industry. Given the popularity of compact cassettes, the headphone-equipped portable stereo, the Walkman, appeared in 1979. This embodied a completely new audio concept. Music, which had previously been limited to within the home, could now be taken outdoors and enjoyed alone anytime, anywhere. This hit product swept the

world, causing a revolution that fundamentally altered the way we listened to music.

This report begins with the history of sound recording, and then touches on the invention of magnetic recording and the development of the early open reel tape recorders in Chapters 2 to 5, before going on to discuss the development of component technologies of the compact cassette tape, such as tape, heads, noise reduction and motors in Chapters 6 to 12. Chapter 13 describes the development of compact cassette equipment and the creation and development of the Walkman, the headphone-equipped portable stereo. Chapter 14 describes the development of digital audio tape recorders (DAT), typified by the compact disc, at the leading edge of technology in the digital audio age.

2 | Recording Sound

2.1 Sound Recording by Scott de Martinville

Writing was invented as human civilisations developed, making it possible to record and pass on various matters. As writing developed, it enabled large amounts of knowledge to be kept on a broad range of areas for a long period of time, facilitating the further advancement and expansion of civilisation. From the dawn of time, writing (and pictures) by humans was the sole means of keeping records. It was the dream of humankind since ancient times to store and reproduce voice and music, or the sounds themselves, but this dream was not readily achieved. Much trial and error took place in the 19th century to achieve this dream based on rapidly advancing modern science and technology, and some major results had been achieved even before the advent of the 20th century.

Sound is a wave that travels through the air; it is a compression wave that alters with time. Accordingly, in order to record sound, it is necessary to record the changes in that wave against a time axis. Based on the idea that sound could be recorded if air density could be captured as an oscillation, French printer Édouard-Léon Scott de Martinville succeeded in recording a waveform in 1857. His device captured sound through a plaster horn and transmitted it to a diaphragm; a pig bristle attached to the diaphragm recorded the sound waveform in lampblack onto a cylinder. The cylinder was turned on its axis with the sound waveform recorded in a continuous line on the surface of the cylinder. This instrument was named the phonautograph; many of these were manufactured as experimental equipment for sound recording (Fig. 2.1). A further improvement was made to the device by wrapping it with paper coated in lampblack, which could then be kept as a recording paper, rather than coating the cylinder itself. While the phonautograph could record sound, it could not play it back, as it had no means to reproduce the original sound from the waveform. However, it excited many scientists and engineers, who became engrossed in trying to invent a machine that could record and play back sound.

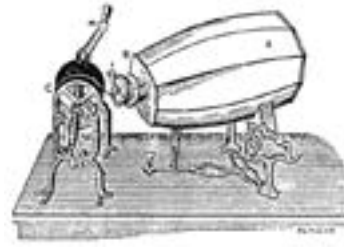

Fig. 2.1. Édouard-Léon Scott de Martinville's "Phonautograph" ⁽¹⁾

2.2 Invention of the Phonograph

In 1877, 20 years after the phonautograph was invented, American inventor Thomas Edison succeeded in making a device that could record and play back sound using a cylinder like the phonautograph. The cylinder was made of brass, wrapped in tin foil and fitted with a handle on its axis. Cylindrical tubes fitted with diaphragms with needles attached were arranged on either side of the cylinder. These tubes worked respectively as a microphone for recording and a speaker for playback. To record sound, one pressed the microphone needle against the cylinder and wound the handle. When one spoke into the microphone tube, the needle would record the sound on the tin foil on the cylinder. To play the sound back, the needle on the playback diaphragm would trace the groove created during recording; the diaphragm would vibrate according to the recorded waveform and convert it back to sound. This was a very clear and simple mechanism. Edison immediately decided to apply for a patent, naming this instrument the "Phonograph" (Figs. 2.2, 2.3). While it seems to have been based on the idea of Scott de Martinville's phonautograph, it was full of original ideas and experimentation, such as using tin foil as a recording media and the unique construction of the diaphragm and needles. The phonograph finally achieved the dream of recording sound for the first time in history. The invention of the "talking machine" immediately became known throughout the world, as did the name "Phonograph". It appeared in an article in a Japanese literary magazine the following year in 1878 with a translated name meaning "voice reproduction device". In 1879, Englishman James Ewing, a lecturer at the University of Tokyo, carried out a public experiment for himself. The president of the Tokyo Nichi Nichi Shinbun newspaper, Genichiro Fukuchi, who attended the experiment, coined the Japanese term *chikuonki* meaning "sound storing device" that later took hold in Japan as the name for the gramophone.

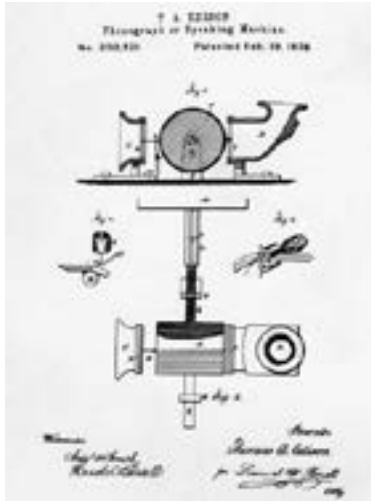

Fig. 2.2. Patent document for the Phonograph ⁽²⁾

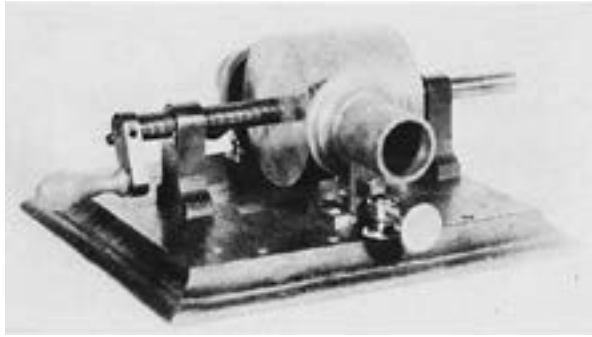

Fig. 2.3. Edison's "Phonograph" ⁽³⁾

for the business model of reproducing recorded discs and selling them in large quantities as records. Creating a mould by carefully reproducing a groove etched into a master disc then using that mould to produce large quantities of copies was the prototype for modern record production. This was vitally instrumental to the development of the recording and music industries. The discs were far more suited to the reproduction process than were the cylinders; this became the trump card to conclude the market battle between the two formats. These records were the mainstay of recorded music until the late 20th century. Technical improvements to disc records continued to develop, such as long-playing capabilities, improved sound quality and stereo sound, although the principle of producing sound by mechanically tracing a groove etched onto a disc remained fundamentally the same as it had been in Berliner's gramophone.



Fig. 2.4. Berliner's "Gramophone" ⁽⁴⁾

2.3 Appearance of Disc Gramophones

There was much interest in the gramophone at the laboratory (later Bell Laboratories) founded by Graham Bell, the inventor of the telephone. Researchers at the laboratory hoped to study improvements to the gramophone; one of these was Emil Berliner. Berliner moved to the United States from Germany at the age of 19 and worked as a technician on research to improve the gramophone. He was greatly impressed and excited by Edison's cylinder phonograph and had a good understanding of its inherent issues. Edison's device recorded sound by etching a waveform onto a cylinder in a vertical direction, with the depth of the groove changing with the volume of the sound. Feeling that this would distort the sound, Berliner came up with a system of etching the waveform in a horizontal direction. Berliner also came up with the idea of using flat, disc-shaped recording media instead of cylinders. Thus, the disc gramophone and gramophone records were conceived in 1887, 10 years after Edison's phonograph. This instrument was named the "Gramophone" (Fig. 2.4), marking a very significant point in the history of sound recording. Berliner did not stop at simply inventing the gramophone, he also devised the basis

References

- (1) Mori, Yoshihisa, et. al. Onkyō-Gijutsu-Shi [History of Sound Recording], Tokyo University of the Arts Press, March 2011, p. 16.
- (2) Ibid., p. 20.
- (3) Ibid., p. 18.
- (4) Ibid., p. 27.

3 | Invention of Magnetic Recording

3.1 The Work of Oberlin Smith

Edison had turned humanity's dream of recording sound into reality. Berliner had improved on the cylinder phonograph, creating the disc gramophone. The invention of the gramophone had implications that went beyond merely recording sound; it created an industry from a new style of entertainment in the form of listening to music at home on duplicated records. The underlying principle of the gramophone was that of mechanically recording a sound waveform onto a medium and reproducing that waveform as an oscillation. Around 1888, American mechanical engineer Oberlin Smith devised and published an idea for a device for recording voices transmitted by telephone based on a completely different principle from that used in the gramophone. Inspired by the phonograph, Smith was the first in the world to come up with the idea of magnetic recording, which differed completely from mechanical recording methods. Believing that more information could be gathered by making this available to the general public, he published his idea in *The Electrical World* without patenting it. The concept of magnetic recording published by Oberlin Smith is given below.

"The following proposed apparatus is, however, purely electrical, and is, as far as known to the writer, the only one fulfilling such conditions that has been suggested. [Fig. 3.1 (a)] is the recording part of an electrical phonograph. [Fig. 3.1 (b)] is the talking part of the same. Many of the pieces, as D, E, B, C, etc., can be the same ones as are used in [Fig. 3.1 (a)]. ... In [Fig. 3.1 (a)] the voice or other sound is delivered into an ordinary telephone A. Preferably, this should be a carbon transmitter so as to have a battery F in the circuit, and thus use as strong a current as practicable. Possibly, however, a Bell telephone without a battery would answer the purpose.

In either case the current, broken into waves of varying lengths and intensities corresponding with the vibrations of the diaphragm in the telephone, passes in its circuit through the helix B, converting into a permanent magnet any piece of hardened steel which may be at the time within the helix. Through this helix B passes a cord, string, thread, ribbon, chain or wire C, made wholly or partly of hardened steel, and kept in motion by being wound on to the reel E from off the reel D, E being revolved by hand, clock-work or other means. J is a tension spring or brake pressing against D to keep the cord C taut.

When in operation with the undulatory current from the telephone A passing through the helix, the cord C becomes, so to speak, a series of short magnets grouped into alternate swellings and attenuations of magnetism.

The actual lengths of these groups depends upon the speed of their motion, but their relative lengths depend upon the relative lengths of the sound wave; and their relative intensities depend upon the relative amplitudes of these waves. The cord C therefore contains a perfect record of the sound, far more delicate than the indentations in the tin-foil of the mechanical phonograph. The probable construction of C would be a cotton, silk or other thread, among whose fibres would be spun (or otherwise mixed) hard steel dust, or short clippings of very fine steel wire, hardened. Each piece would, of course, become a complete magnet. Other forms of C might be a brass, lead or other wire or ribbon through which the steel dust was mixed in melting—being hardened afterwards in the case of brass or any metal with a high melting point. ... Another imaginable form of C would be simply a hard steel wire, but it is scarcely possible that it would divide itself up properly into a number of short magnets. ... If it could be made to work it would obviously be the simplest thing yet suggested."

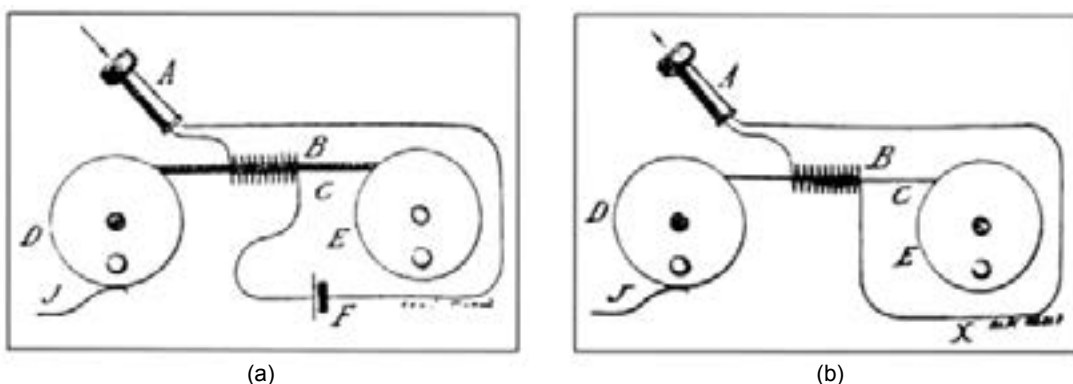

Fig. 3.1. Oberlin Smith's Wire Recorder Idea

Excerpt from Smith's article in *The Electrical World*, 8 September 1888.

(50 Years of Audio, 1986. Japan Audio Society Publishing, reprint. English text excerpt taken from [http://oberlinsmith.org/Library/Library-PDFs/The Electrical World 8 Sep 1888.pdf](http://oberlinsmith.org/Library/Library-PDFs/The_Electrical_World_8_Sep_1888.pdf), accessed 19 December 2012.)

3.2 Invention of the Wire Recorder

The publication of Oberlin Smith's idea was truly groundbreaking in terms of technological developments in magnetic recording. Many engineers were inspired by this article and set about trying to develop magnetic recording devices. In 1898, 10 years after Smith published his idea, Danish telephone engineer Valdemar Poulsen invented the world's first magnetic recorder, using steel wire as a recording medium. This device, shown in Fig. 3.2, is very similar in structure to Edison's phonograph, except that the cylinder is wrapped in steel wire rather than tin foil or wax and it has an electromagnet touching the wire. This magnet plays the same role as the needle used in the phonograph. As the cylinder revolves, the magnet runs along the wire, using continuous magnetisation to record sound on it. To play back the sound, the magnetised wire is run through the same electromagnet, allowing the recording to be reproduced as an electrical current induced in the coil through magnetisation. Poulsen called this instrument the "Telegraphone". As a telephone engineer, he apparently intended to record voices transmitted by telephone (an answerphone, so to speak). Poulsen gained patent rights for the telegraphone in Denmark, the United States, the United Kingdom, France and other key countries and embarked on a major marketing campaign for it. Although the telegraphone had promising prospects with a well-received exhibit at the Exposition Universelle in 1900 in Paris, it failed as a business venture, as the products were fraught with problems: the quality was not good enough, they were prone to breaking down, and it was difficult to achieve the desired sound quality. The improved development and performance of the disc recorders and the popularity of the record industry boosted the dominance of the gramophone and the magnetic wire recorder was largely forgotten by the public. Poulsen and his assistants worked hard to improve the performance of magnetic recording and achieved some results that would later become relevant, such as the invention of DC bias.



Fig. 3.2. Poulsen's "Telegraphone" ⁽¹⁾

3.3 Invention of DC Bias

While the telegraphone business venture failed to take off, Poulsen and his assistant Peder O. Pedersen worked hard to improve the telegraphone. In 1907, they acquired

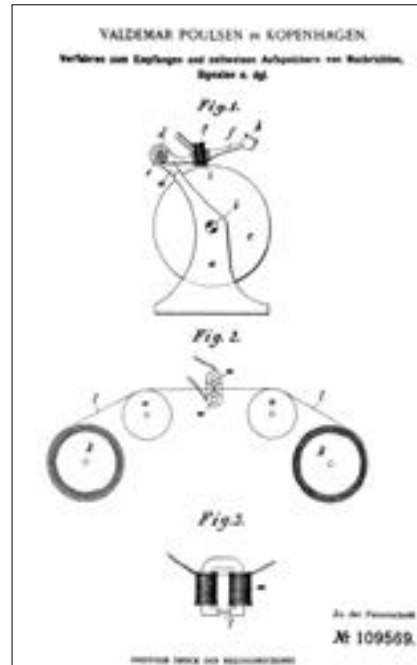

Fig. 3.3. Poulsen's Telegraphone patent ⁽²⁾

patent rights in the United States for their DC bias system. The DC bias technology was very effective in improving sound quality by increasing the sensitivity of the recording and reducing distortion. It became an essential piece of technology for magnetic recording in devices such as the wire recorder for the next 30 years until AC bias was invented.

When a magnetic field is externally applied to a magnetic substance and gradually strengthened, the internal magnetic flux of the magnetic substance also increases; however, it only increases to a certain extent. The magnetic flux at this point is called the maximum magnetic flux density (B_m). If the external magnetic field is reduced to 0 at this point, the magnetic substance retains its internal magnetic flux density rather than also returning to 0. This means that the magnetic substance has become a magnet (it has become magnetised). This magnetic flux density is called residual magnetic flux density (B_r); the substance will never become a stronger permanent magnet than it is at this point. The north pole of a magnet created through magnetisation in one direction would have become the south pole of the magnet if the magnetisation were to have taken place in the opposite direction. The magnetic field forms a symmetrical curve corresponding to the strength of the magnet, as shown in Fig. 3.4. This curve is called the magnetisation curve or hysteresis curve.

When a completely non-magnetised material is magnetised, the magnetization follows the 0-a, 0-c curve shown in Fig. 3.4. In the initial stage, this curve is called the initial magnetisation curve. In a magnetic recorder, the horizontal axis corresponds to the recording magnetic field applied to the magnetic material (wire, later magnetic tape) by

the head, while the vertical axis shows the intensity of the magnetisation. The magnetic field produced by the head is in proportion to the strength of the recording signal, that is, the recording current flowing through the head. Since the initial magnetisation curve is not a straight line, the result of magnetisation will be a distorted waveform even if a magnetic field is applied according to the sound being recorded. This is called unbiased recording, shown in Fig. 3.5. Significant distortion occurs where a recording is made where the magnetisation curve is not in a straight line. Having the recording current as DC and using a near-straight magnetisation curve reduces distortion and produces better sound quality. This is called DC bias recording. While using straight-line section a of the magnetisation curve shown in Fig. 3.6 reduces distortion, as shown in Fig. 3.7, if we look at the overall magnetisation curve, we see that section b on the outer loop is a longer straight-line section, so it would be better to use section b. First, a magnetic substance is applied to a saturation field to create B_r ; the substance is then biased in one direction without reducing the magnetic flux density; the recording current is then added and DC bias recording can be achieved using section b, as shown in Fig. 3.8. This was the DC bias method invented by Poulsen and Pedersen, achieving good recording quality by using long straight sections of the magnetic curve.

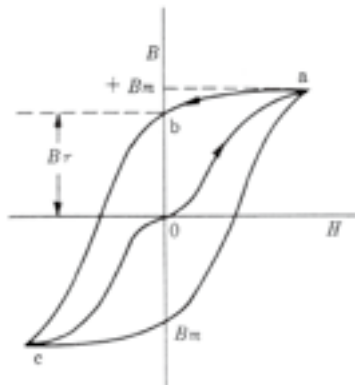

Fig. 3.4. Magnetisation curve ⁽³⁾

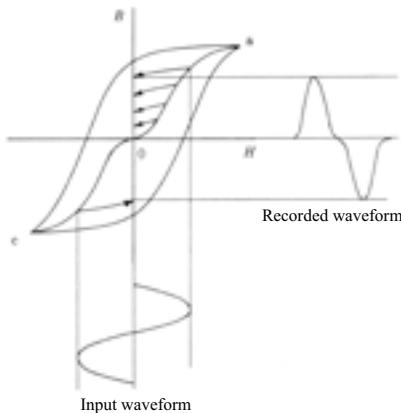

Fig. 3.5. Distortion due to unbiased recording ⁽⁴⁾

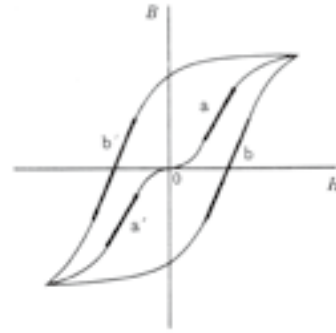

Fig. 3.6. Straight line section of magnetisation curve ⁽⁵⁾

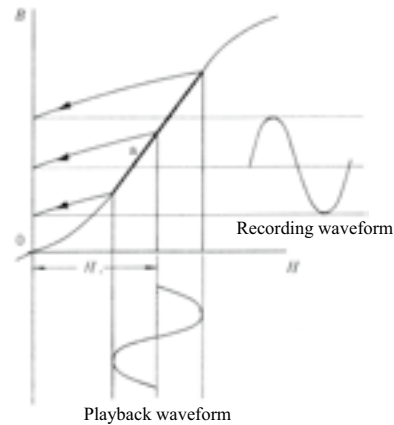

Fig. 3.7. DC bias recording ⁽⁶⁾

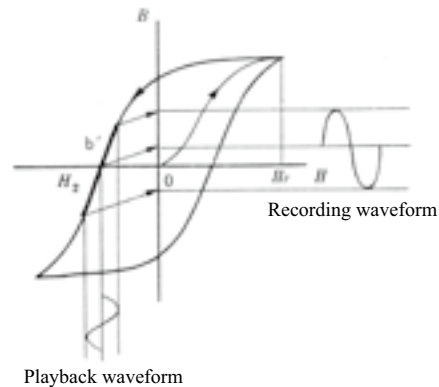

Fig. 3.8. DC bias recording 2 ⁽⁷⁾

3.4 Advances in the Wire Recorder

Poulsen continued working hard to promote the wire recorder, setting up a sales company in the United States in the hope of popularising it. He also continued to make improvements to the telegraphone itself, but he was never able to dominate the market because the device was lacking both in terms of competitive pricing and in the degree of technical perfection required for ease of use and good performance. The wire recorder failed as the popular choice of sound recorder due to the growth and development of the disc gramophone. However, by the late 1920s there was a growing interest in magnetic recorders in fields such as broadcasting and military

communications and further research began to be carried out, especially in the West. One feature of the wire recorder was that it could play continuously for longer periods than records; there was a demand in these fields for such a feature. These recorders were actually implemented in some areas in Europe, such as the large, steel ribbon recorders used in broadcasting, which replaced the steel wire with steel foil as the recording medium. Fig. 3.9 shows an improved telegraphone from around 1920. This is an archetypal tape recorder, with the wire-wound reel driven by a motor and use of the left and right reels alternating when the recorded wire is rewound. Fig. 3.10 shows a British Marconi-Stille steel ribbon recorder used for broadcasting by the BBC. This huge device weighed one tonne and could record for 30 minutes on a steel ribbon that was 3mm wide, 80µm thick and 3,000m long. One of these was imported by Japan in 1937 and used for foreign-language broadcasting by NHK Tokyo.



Fig. 3.9. Telegraphone, circa 1920⁽⁸⁾



Fig. 3.10. Marconi-Stille steel ribbon recorder (1937)⁽⁹⁾

3.5 Invention of the Tape Recorder

3.5.1 Sound Paper Machine

The wire recorders and steel ribbon recorders were certainly not easy to use. They used solid metal recording media; if the wire came unwound it was extremely difficult to put it back; if it broke, it had to be welded back together. It is not difficult to imagine that the question was often posed

of whether a more suitable material could be used as a recording medium for a magnetic recorder that was easier to use and could overcome these drawbacks. Although the idea to coat a tape of soft material with a powdered magnetic substance was proposed by A. Nasavischwily in Germany and Joseph A. O'Neill in the United States in the 1920s, nobody had managed to build a working machine. In 1928, German engineer Fritz Pfeumer coated paper tape with iron oxide to create a "recording tape" and made the world's first tape recorder, called the "Sound Paper Machine". While this machine had all the basic elements of a tape recorder and could be hailed as the world's first tape recorder, it crucially lacked in performance and could not produce a satisfactory quality of sound. The coated magnetic tape did not have an even surface and the coating was not very well attached; during playback the magnetic particles would scatter on coming into contact with the head. Due to this, it became known as the "Sandpaper Machine".



Fig. 3.11. Fritz Pfeumer's "Sound Paper Machine"⁽¹⁰⁾

3.5.2 Creation of the Magnetophon

Pfeumer was granted patent rights in 1930 and took the world's first tape recorder to all of the major electrical manufacturers in Germany to try to market it, but could not raise much interest because despite the potential of the technology, it lacked in performance. However, in 1932, the president of Allgemeine Elektrizitäts-Gesellschaft (AEG) showed some interest, buying the patent rights from Pfeumer. AEG immediately set up a research laboratory on magnetic recording and set about improving the Sound Paper Machine and the magnetic tape. Being an electrical manufacturer, AEG needed experts in chemistry to improve the magnetic tape and sought assistance from IG Farben. Consequently, the IG Farben's Ludwigshafen factory (later BASF) ended up collaborating on the magnetic tape project. While IG Farben worked on developing the tape, AEG put its efforts into research and development of the magnetic recorder, completing the forerunner to the modern tape recorder – the "Magnetophon" – in 1934 (Fig. 3.12). AEG

planned to exhibit it at a radio show that year, but several defects were discovered in the drive train and the amplifier right before the show, so the exhibit was withdrawn. AEG made further improvements to the drive mechanism and other parts and enclosed the mechanism unit, the amplifier unit and the speaker unit in separate housings. The combined system went on display at the Berlin Radio Show in 1935 as the “K1 Magnetophon”. The world’s first practical tape recorder and magnetic tape was successfully demonstrated in public. As well as having high-quality tape developed by a specialised manufacturer, it had a stable tape drive system and ring heads



Fig. 3.12. An early Magnetophon (ca. 1934) ⁽¹¹⁾

that would not put excess pressure on the tape and damage it. These developments meant that the Magnetophon had most of the elements of a modern tape recorder.

3.5.3 Popularity of the Magnetophon

AEG developed a range of other models after the K1 Magnetophon, such as a console model and a portable model. These began to be used for monitoring radio broadcasts and recording military and police interrogations. While broadcasting offices mainly used disc recorders, most of the broadcasting offices in Germany had Magnetophons installed by the outbreak of the Second World War in 1939. The adoption of AC bias in 1942 made a major improvement to the sound quality, which had previously not been as good as the disc recorders. High-quality, pre-recorded broadcasts began to be transmitted all across Europe. The Allied Forces, thinking that such a high quality broadcast could only be live, were mystified at how these shows could be broadcast continuously (Fig. 3.13).

Although the Magnetophon gained popularity in Germany as a new, high-quality recorder, all international technology exchange stopped at this time, as the machine with its broadcasting and recording uses would be particularly helpful to the military. The main sound recorders in the West at the time were the disc recorders; while there were some steel wire/ribbon recorders in use, they were not really practical recording machines. Magnetophon technology was clearly

superior for recording sound. The Second World War ended in 1945 with an Allied victory. Magnetophon technology was analysed by the Allies, leading to the development of highly efficient tape recorders in the United States.



Fig. 3.13. Magnetophon (1943) ⁽¹²⁾

3.6 Discovery of AC Bias

3.6.1 American Research

Around 1920, the United States Naval Research Laboratory was researching how to reduce telegraph transmission times using magnetic recording. The idea was that recordings made at normal speed could be transmitted at high speed and recorded at high speed at the receiving end, thereby reducing the transmission time. Although this was never implemented due to the difficulty of high speed recording, AC bias was discovered by chance during the course of this research. In 1921, laboratory researchers Wendell Carlson and Glenn Carpenter discovered the AC bias effect while experimenting with magnetic recording when their amplifier oscillated unexpectedly, acting as a high-frequency bias. This invention was patented in the United States in 1927. Although this should have radically improved the performance of magnetic recording, it was overlooked as a means of improving recording, being primarily used for noise reduction.

In the mid-1930s, Bell Laboratories carried out some research on AC bias with a view to improving the performance of steel wire/ribbon recorders. In 1937, Bell Labs developed the endless-loop style “Mirrophone”. A stereo-capable model using AC bias was demonstrated at the 1939 New York World’s Fair. Dean E. Wooldridge of Bell Labs put in a patent application for the results of the AC bias research in 1939 and a US patent was registered in 1941. The patent was later given over to Marvin Camras from the Armour Institute/Illinois Institute of Technology and an

improved version, later known as the Camras Patent, made a big impact in the world of magnetic recording. While AC bias was rapidly adopted by Armour Institute in 1941 for use in wire recorders for the navy and other applications, the sound recorders themselves still had the usual performance/function limitations of wire recorders.

3.6.2 Research in Germany

While Germany had built the first modern tape recorder in the form of the Magnetophon, by around 1930, all magnetic recorders, including steel wire/ribbon recorders, were using the DC bias method invented by Poulsen.

In 1938, the German state broadcasting company made the decision to use the K4(S) Magnetophon for broadcasting. Dr Hans-Joachim von Braunmühl, chief engineer of the state broadcaster's research laboratory, appointed Walter Weber to the task of improving the quality of the Magnetophon. In 1939, while experimenting with circuits, Weber discovered by chance how high quality recording and playback could be achieved, radically improving sound quality in terms of frequency response, noise and distortion. Weber knew that this improvement was caused by abnormal oscillation in the recording circuit and eventually managed to make a recording using AC bias by chance. He spent some time examining the idea and formalised the AC bias method in 1940. In July that year he applied for a German patent.

The adoption of AC bias saw rapid improvement in the performance of the Magnetophon, producing far greater recording and playback quality than could be achieved through DC bias. AEG prepared to introduce AC bias to the wider community by staging public demonstrations and other activities. In 1942, AC bias was used in Magnetophons for broadcasting. This enabled pre-recorded broadcasts of extremely high quality for the time to be transmitted all across Europe up until just before the war ended.

3.6.3 Research in Japan

Japanese research on magnetic recording began in the late 1920s. Dr Kenzo Nagai of the Tohoku University Faculty of Engineering, who was researching voice delay devices with the idea that they would be useful in studying submarine acoustics, began researching magnetic recording after coming up with the idea of using a proposed recording on an endless steel wire as a delay device. This research developed into a study on the wire recorder and followed on to applied research, such as on proposed secret communications using magnetic recording. With collaboration from the university's Institute for Materials Research, Nagai studied the most suitable material to use for wire recording and the Institute for Materials Research developed a magnetic material called Sendai Metal (an alloy of 40% steel, 40% nickel and 20% copper) which was very good for recording. In 1936, Nagai

also carried out an experimental "pre-recorded broadcast" with NHK Sendai. Following on from this, he also successfully made a live recording of whaling in the sea off Kinkasan with collaboration from Anritsu Electric. Although he used a trial wire recorder for this experiment, it succeeded in recording aboard a rocking boat, which was impossible to do with a disc recorder. It was quite a long recording and had to be edited down to around ten minutes for broadcasting. Although it was quite a difficult task to cut and re-join the thin wire, it meant that pre-recorded broadcasts were now possible in an age in which live broadcasting was the norm. However, there was a lot of background noise in the recording and so pre-recorded broadcasts were deemed unsuitable for regular use in broadcasting. Accordingly, Nagai's laboratory then set about researching noise reduction. Teiji Igarashi, a researcher from Nagai's laboratory who had gone to work with Anritsu, was also researching applications for magnetic recording at this time. Igarashi discovered AC erasure by chance in an experiment and confirmed that this drastically reduced background noise. Although it did not improve sound quality, it was able to reduce noise without needing the existing method of DC erasure and was thus granted a patent. This motivated Igarashi to repeat the experiment to optimise the process by altering the AC frequency and intensity, thus perfecting the AC bias method. Given the fact that Nagai had achieved the same approximate results earlier than Igarashi and Anritsu had had technical advice from Nagai from the beginning, Anritsu Electrical and Nagai jointly applied for an AC bias patent, which was granted in 1940.

3.6.4 AC Bias

AC bias is a method of recording in which a higher frequency signal (the bias signal) is recorded along with the recording signal. This method produces a better quality of magnetic recording than DC bias and is an indispensable means for improving the performance of modern tape recorders. This technology is now used in all analogue tape recorders. The higher the frequency of the superimposing bias signal, the greater the expected performance; yet wavelengths of between 30 kHz and 200 kHz are generally chosen, taking into account the saturation of the head.

As shown in Fig. 3.14, the recording current flowing through the head during AC bias recording takes a waveform such as (c), produced by recording input signal (a) superimposing with bias signal (b). Recording should be achieved by this signal being applied to the head and the tape passing through the gap in front of the head. However, when a high frequency bias current is superimposed with the input signal (here, the sound current), a recording current as shown in Fig. 3.15 (B) flows through the head, generating an alternating magnetic field. Looking at one point on the

Table 3.1. AC Bias Patents ⁽¹³⁾

Application Year	Month	Day	Patent Year	Month	Day	Country	Patent No.	Name of Invention / Thesis	Inventor	Accepted	Notes
1902	Jun	12	1907	Dec	10	USA	879,083	Telephone	Valdemar Paulsen Peder O. Pedersen	111,305	DC bias patent
1921	Mar	26	1927	Aug	30	USA	1,640,861	Radio Telegraphone System	Wendel C. Carlson Ollen W. Carpenter	456,020	AC bias patent
1936	Jun	05				Japan	The Journal of the Institute of Electrical Communication No. 180	A Study of Noise in Magnetic Recording Systems	Kenzo Nagai, Shiro Sasaki, Junosuke Endo		AC erasure
1936	Oct	12	1937	Feb	03	Japan	119,071	Magnetic Recording Devices Not Requiring Peripheral Equipment	Teiji Igarashi, Saburo Utsugi Patent held by Anritsu Electrical Co., Ltd.		AC erasure and AC bias patent
1938	Feb	05				Japan	The Journal of the Institute of Electrical Communication No. 7	An Experimental Examination of the AC Blowout Method in Magnetic Recording	Kenzo Nagai, Shiro Sasaki, Junosuke Endo		AC erasure
1938	Mar	14	1940	Jun	21	Japan	136,997	A Magnetic Recording System Having AC as a "Bias"	Teiji Igarashi, Makoto Ishikawa, Keizo Nagai Patent held by Anritsu Electrical Co., Ltd.		AC bias patent
1939	Jul	29	1941	Mar	18	USA	2,235,132	Magnetic Telegraphone	Dean E. Woodridge (assignor: Bell Telephone Lab)	287,192	AC bias patent
1940	Jul	28	1943	Nov	04	Germany	743,411	Verfahren zur magnetischen Schaaaufzeichnung	Hans J. von Braunmühl Walter Weber		AC bias patent
1941	Oct	02	1943			USA		Method of Magnetic Sound Recording		413,380	Same patent applied for in USA
1941	Dec	22	1944	Jun	13	USA	2,351,004	Method and Means of Magnetic recording	Marvin Camras (assignor: Armour Research Foundation)	423,928	AC bias patent

tape that has passed through, the magnetic field changes, as shown in Fig. 3.16, and the final magnetisation is recorded (the south pole in the case shown in Fig. 3.16). Since the strength of the magnetisation is proportionate to the input signal, it is possible to record with very little distortion. This is represented on curve B-H in Fig. 3.17, which shows the changes in the magnetic field affecting the tape. AC bias recording means that the tape is temporarily magnetised to saturation, so that recording can take place irrespective of the initial magnetisation curve. Where the input signal is 0, the tape magnetisation is also 0, meaning it has been AC erased.

Sections 3.6.1 to 3.6.3 discuss the progress of research in various countries. It is interesting to note that in each case an unexpected oscillation in the amplifier during an experiment caused a successful result purely by chance. In each case, researchers also came to the conclusion that erasing residual magnetisation would produce better recording quality. While AC bias could be considered to be a more intuitively elusive phenomenon than DC bias, it was made to work by chance and ended up becoming a vital technology that vastly improved the recording quality of tape recorders.

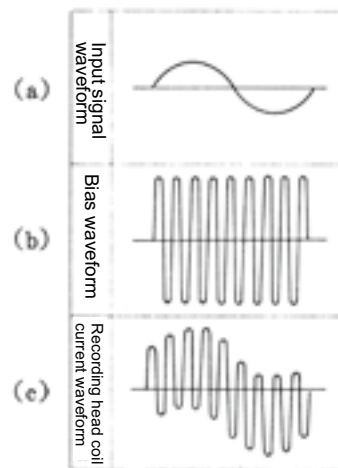

Fig. 3.14. AC bias recording waveforms ⁽¹⁴⁾

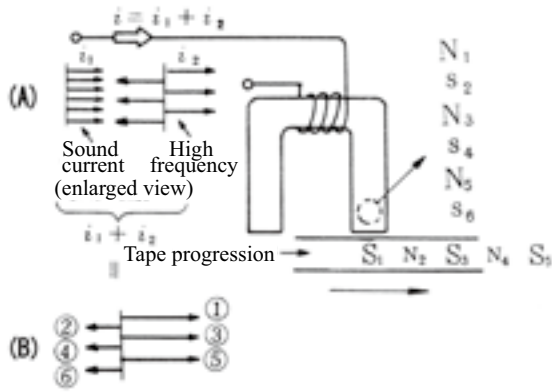

Fig. 3.15. Tape magnetisation process⁽¹⁵⁾

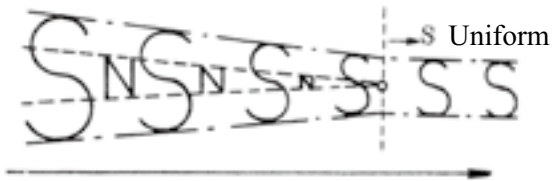

Fig. 3.16. Residual magnetisation at a certain point on the tape⁽¹⁶⁾

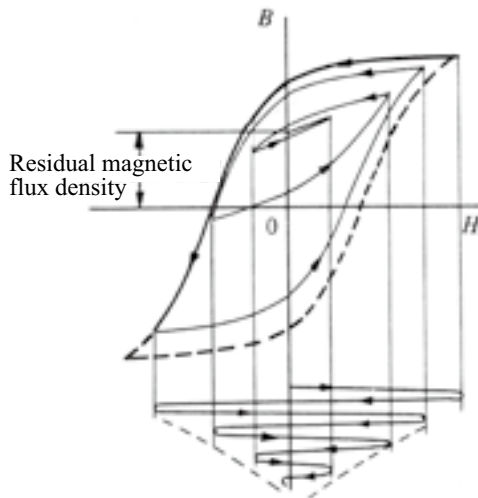

Fig. 3.17. Magnetic field temporarily reduced through AC bias⁽¹⁷⁾

References

- (1) Mori, Yoshihisa, et. al. Onkyō-Gijutsu-Shi [History of Sound Recording], Tokyo University of the Arts Press, March 2011, p. 73.
- (2) Ibid., p. 73.
- (3) Tēpurekōdā no Kiso [Tape Recorder Basics]. Sony Inc. Technology Education Center, May 1985, p. 34.
- (4) Ibid.
- (5) Ibid., p. 35.
- (6) Ibid., p. 36.
- (7) Ibid.
- (8) Abe, Yoshiharu. “Tēpu Rokuon-ki Monogatari Sono 1 [The Story of the Tape Recorder 1]”, JAS Journal 2004, Vol. 44, No. 7.
- (9) Ibid.
- (10) Abe, Yoshiharu. “Tēpu Rokuon-ki Monogatari Sono 2 [The Story of the Tape Recorder 2]”, JAS Journal 2004, Vol. 44, No. 8 & 9.
- (11) Ibid.
- (12) Abe, Yoshiharu. “Tēpu Rokuon-ki Monogatari Sono 1 [The Story of the Tape Recorder 1]”, JAS Journal 2004, Vol. 44, No. 7.
- (13) Abe, Yoshiharu. “Tēpu Rokuon-ki Monogatari Sono 33 [The Story of the Tape Recorder 33]”, JAS Journal 2004, Vol. 48, No. 5 & 6.
- (14) Tēpurekōdā no Kiso [Tape Recorder Basics]. Sony Inc. Technology Education Center, May 1985, p. 37.
- (15) Ibid.
- (16) Ibid.
- (17) Ibid., p. 38.

4 | Post-war Tape Recorders

4.1 United States

4.1.1 Creation of Ampex

In July 1945, two months after Germany surrendered, John Mullin of the US Army Signal Corps encountered the Magnetophon at a radio station on the outskirts of Frankfurt. Mullin, who had been investigating German communication technology, was captivated by its performance capability. By the end of the year, he had acquired several machines and dozens of tapes, immediately sending them off to the United States for a more detailed analysis. With the help of a friend at home in San Francisco, Mullin set about repairing and improving the confiscated Magnetophons, replacing the DC bias system with AC bias (the Magnetophons he acquired were the old K4 models that used DC bias) and redesigning the electrical circuits and began to make some test music recordings (Fig. 4.1). He created a major stir on 16 May 1946 when he demonstrated his new and improved Magnetophon at a meeting of the IEEE in San Francisco.



Fig. 4.1. Mullin's improved Magnetophon⁽¹⁾

Despite being a small-scale start-up company, Ampex Co., Ltd. was very interested in this demonstration and set about developing its own model with a firm belief in its potential. While it was difficult to set a direction and goals for this project to develop a completely new product, the company was able to develop a playback head with advice from Mullin. With positive cooperation from Mullin, such as providing his own Magnetophon until the company was able to develop a drive train, the playback head developed by Ampex did wonders for the performance of the Magnetophon. The company then worked on other developments, such as a recording and an erase head, and managed to complete the Ampex 200 model by 1948 (Fig. 4.2). As pre-recorded broadcasts began to dominate American airwaves, it was

a major concern for the “Bing Crosby Show”, a popular radio programme at the time that was on its way to being broadcast nationwide, to maintain the sound quality of the recording. Bing Crosby staff members investigating the use of the Magnetophon for making high quality pre-recorded broadcasts were very interested in the Ampex 200 demonstration and offered to help with getting the system introduced to radio stations. Being a newly founded company, Ampex had no marketing channels through which to target radio stations. It signed an agreement for the marketing to be carried out by Bing Crosby Enterprises and soon the Magnetophon was being delivered to the ABC to be put to use in radio broadcasts. With the 200 model accepted for use by radio stations, Ampex released the improved 300 model in 1949, establishing its firm standing in the field of tape recorders for business use. Compared with the existing disc recorders, the machine was ground-breaking in terms of its sound quality, ease of use and ease of editing. Its popularity immediately spread to other areas such as recording studios and movie sound recording.



Fig. 4.2. AMPEX 200⁽²⁾

While Ampex developed the 200 model tape recorder, disc recorder manufacturers Audio Device and 3M appealed to Ampex to provide information and guidance in developing tape media. The Magnetophon had given these companies a glimpse of the huge potential of magnetic recording, that is, the tape recorder, in place of the disc recorder and they were very interested in magnetic tape as a new product. While 3M had no experience with recording equipment, it was a very experienced chemical developer, and made a full-scale entry into the field of magnetic tape, developing the famous “Scotch Magnetic Tape”. The company’s superior technical competence enabled the production of magnetic tape that offered extremely stable performance for its time. It produced

the famous “Scotch 111”, which became the standard tape for tape recorders all over the world (Fig. 4.3).



Fig. 4.3. Scotch 111 magnetic tape⁽³⁾

4.1.2 Opposition to Ampex: the Magnecorder

While Ampex was working on developing the tape recorder, several other US companies also began developing this new recording technology. While some companies became interested after being inspired by Mullin’s demonstration of the Magnetophon, others were working on developments completely unrelated to the Magnetophon. Magnecord, a Chicago company founded in 1946, introduced the SD-1 wire recorder as its first product and continued developing new products. With a strong proposal from the sales end, the company put its steel wire development on hold and started working on tape recorders. In May 1948, the company exhibited its first prototype at the NAB Show, gaining considerable popularity. This machine was called the PT-6 (Fig. 4.4) and was priced far lower (\$499.50) than the Ampex 200 (\$3,825). Its small casing also attracted more user interest than the large, console-style 200. While the Ampex 200 had a three-head configuration allowing recordings to be monitored for business use, the PT-6 was not really suitable for business use, having only two heads: one for erasing and one for recording/playback. Two heads became the standard configuration for household tape recorders, as cost was an important factor and the two-head configuration offered the basic recorder functions. Nevertheless, the Magnecorder switched to three heads in 1950 to meet the demand for a proper business machine.



Fig. 4.4. Magnecorder PT-6 (1948)⁽⁴⁾

In 1949, a Hawaiian Japanese radio station brought a Magnecorder and some Scotch 111 magnetic tape to NHK in order to record the popular amateur singing radio programme “Nodojiman Shiroto Ongakukai”. In August that year, several Magnecorder PT-6s that had been used in relay

recordings of the national aquatics championships in Los Angeles were brought to Japan by an NHK engineer and tape recorders began to be used in radio broadcasting in earnest. From 1951, the post-war-founded commercial broadcasters began to use the PT-6. Thus the Magnecorder was the first tape recorder to be brought to Japan and put to practical use. This machine provided much inspiration for domestic tape recorder development within Japan.

4.1.3 Unified Standards

A great number of companies appeared in the United States between 1947 and 1950, manufacturing and marketing tape recorders firstly as business machines used by broadcasters and also for household use. While some of these were well-established business equipment companies that had been making disc recorders since the pre-war era, some of them were new players attracted by the new market. With multiple manufacturers producing tape recorders according to their own standards, there was little compatibility between recorded tapes. This limited their scope of use and presented an obstacle to the advancement of this long-awaited technology. As tape recorders became more widely used in broadcasting, this issue clearly worsened. Since radio broadcasts had been popular in the pre-war days, there was an association of commercial broadcasters in the United States called the National Association of Broadcasters (NAB)*. Given the use of sound recorders in broadcasting, the NAB had already established the Recording and Reproducing Standards Committee in 1941 for the disc recorders. In 1949, this committee extended its jurisdiction to regulate the necessary terms, measurements and characteristics of tape recorders as well. The NAB standards became the de facto global standards for consumer use as well and were implemented as national standards in many countries around the world. This ensured a minimum level of compatibility in the open-reel era.

* The National Association of Broadcasters, an association of commercial broadcasters in the United States, was established in 1923, having thus been in existence for 90 years. The NAB holds an annual convention in the United States as well as world’s largest exhibitions of broadcasting equipment (many of the recent exhibitions have been in Las Vegas). The Recording and Reproducing Standards Committee exists within the organisation of the NAB. Following the Second World War, this Committee set the standards for disc and tape recorders for broadcasting use and, together with the RMA (later RTMA, now EIA), has long been known in Japan for these tape recorder standards.

4.2 Europe

4.2.1 Revival of the Magnetophon

Although Germany was home to the advanced technology that produced the Magnetophon, its defeat in the Second World War left its magnetic recorders lagging behind. As an advanced chemical product, magnetic recording tape had been produced by the major chemical manufacturers and was in frequent use by broadcasters for pre-recorded broadcasts in pre-war Germany. After the war, the production of magnetic recording tape in Germany was resumed by Agfa in 1949 and BASF in 1950.

In 1954, nine years after the war, the freshly-outfitted Magnetophon M5 (Fig. 4.5) was finally released by Telefunken, a subsidiary of AEG, for semi-professional use, followed by a model for home use in 1958. In 1952, AEG released the KL-15D, a combined record player and tape recorder for home use. While the Magnetophon was thus revived several years after the war, a significant portion of its tape recorder technology was publicly known and other European manufacturers who had previously worked with steel wire recorders and other technology were now developing their own tape recorders and putting them on the market. The tape recorder was advancing across Europe as a business machine, with British company EMI producing the BTR/1, a copy of the Magnetophon for professional use in 1948 and Swiss company Studer producing the Dynavox for semi-professional use in 1949.

4.2.2 Activity by Studer

Studer was a small electronics manufacturer founded in Zurich, Switzerland in 1948 by Willi Studer. Not long after its founding, Studer began to import tape recorders from the United States, inspiring the company to make its own developments on the tape recorder. It started out by remodelling the imported American tape recorders to European specifications and completed its first tape recorder in 1949: the Dynavox. Although it was a small-scale company with limited human resources, equipment and capability, it succeeded somewhat in business due to the novelty of the tape recorder. With this experience under its belt, the company improved its design and released the T26 in 1951, under the new brand name of Revox. While the Dynavox and the T26 were developed and marketed as general use (albeit highly-priced) tape recorders, Studer developed the 27 model, based on the T26, as a tape recorder for business use. This machine was trialled at music events and was favourably received. In 1952, the Studer 27 went into full-scale production (Fig. 4.6). Through the success of the Studer 27, the company gained a reputation as a manufacturer of business-use tape recorders, leading the

post-war high-end tape recorder market together with US company, Ampex. The Revox brand produced a succession of high-quality tape recorders for general use. The 36 series, which originated in 1955 with the A36, had stereo capability and continued to dominate the market through to 1967, when music lovers and audiophiles fell for the sound quality of the A77 (Fig. 4.7), considered to be the best general use tape recorder at the time. Despite being very highly priced, it was extremely popular, with hundreds of thousands sold all over the world.



Fig. 4.5. Magnetophon M5 (1954) ⁽⁵⁾



Fig. 4.6. Studer 27 (1952)⁽⁶⁾



Fig. 4.7. Revox A77⁽⁷⁾

4.2.3 Appearance of “Nagra”, the Portable Tape Recorder

While the tape recorder was a magnetic recording device and relied more heavily on electrical systems than the gramophone, the major factors determining its performance in the pre-digital-recording era were the tape drive system and the mechanism allowing accurate and stable operation. It was a precision instrument requiring a high working accuracy and an assembly system, so there was no better place for it than Central Europe, where the watchmaking industry had developed. Studer was founded in Switzerland, yet it was another Swiss company in Lausanne that produced a unique recorder exemplary of post-war Europe: the Nagra. Warsaw-born Stefan Kudelski left his homeland of Poland during the Second World War. He eventually settled in Switzerland after living in Hungary and France. In 1951, in Lausanne, Kudelski built a small, lightweight, portable tape recorder with a focus on sound quality. He named this machine Nagra, meaning “to record” in Polish. The first Nagra I was bought by a local radio station in 1952. Although radio stations in

other areas also placed orders for the Nagra I, it was little more than a prototype model and had a number of defects. Kudelski completed the significantly-revised Nagra II (Fig. 4.8) and began to manufacture this model by the end of 1953. Though portable, the Nagra had a very precise and technologically advanced tape operation system and presented a wealth of possibilities to diversify the scope of the tape recorder. The Nagra III debuted in 1959; this model had a systematic operation function, which could be used in synchronisation with a cine-camera for cinematography, for example. The Nagra continued to rank highly as the high-performance portable business machine of the tape recorder industry, used by film studios and broadcasting stations throughout the world. Brimming appeal with its maintenance-oriented design for business use, its precisely-manufactured parts and the sharp, unique feel of its operation, the Nagra became the landmark design for many tape recorder designers. As an integrated system with a number of peripheral devices for synchronisation with cinematography, it enjoyed a long reign as the main sound recording equipment used on film sets. The Nagra’s role in this industry finally came to an end as digital recording equipment and digital voice processing rapidly replaced analogue equipment.



Fig. 4.8. Nagra II (1953)⁽⁸⁾

4.3 Development in Japan

4.3.1 Domestic Production of Tape Recorders for Business Use

Although Anristu and Nippon Electric Company (NEC) began to develop and manufacture steel wire recorders around the late 1930s, they lacked development experience in many areas, such as sound quality and operation; as a result, they were not able to produce anything capable of being used in broadcasting in the pre-war era. The fact that NEC launched a steel wire recorder in 1948 indicates that development had continued during the war; however, the recorder was not widely popular as it was very expensive (Fig. 4.9).



Fig. 4.9. NEC MR-1 steel wire recorder (1948)⁽⁹⁾

As mentioned in Section 4.1.2, the use of tape recorders in Japanese broadcasting started in 1949 with the American Magnecorder. The PT-6 model used was brought to Japan by NHK. Using this model as a reference and with collaboration from NHK, Tokyo Tsushin Kogyo (“Totsuko”, later Sony) and Nippon Denki Onkyo (later Denon) started working on a domestically-produced tape recorder. Development had finally begun on a Japanese-made tape recorder. Denon was an established company with various achievements as a domestic manufacturer of recording equipment for broadcasting both before and after the war, including supplying disc-style recorders to NHK. Its roots were in the Denki Onkyo Research Institute founded by Koichi Tsubota before the war to work on domestic disc-style recorder production. Tokyo Tsushin Kogyo, on the other hand, was a new company, founded by Masaru Ibuka in 1946, that had developed and marketed several measuring instruments for electrical engineering and was constantly looking to work on innovative new products. Respective company founders Tsubota and Ibuka were contemporaries at the Waseda University Faculty of Science and Engineering, although it is not known to what extent the two men knew each other.

Both companies built prototype tape recorders within a short space of time (Figs. 4.10, 4.11), which were then evaluated by NHK. The results of this evaluation were reflected in the official demands that were submitted, while the prototypes were redesigned to meet NHK specifications. The prototypes were introduced by NHK in 1951 as the PT-11 (Fig. 4.12) and PT-12 (Fig. 4.13), the first domestically-produced tape recorders for business use, and were put to use by broadcasting stations all over Japan. It seems that the machines were treated as “portable”, with the tape transporter and amplifier each in separate casings. Photographs of the prototypes show the differences in approach between the two companies. Denon, with its wealth of experience in the field of broadcasting equipment through its disc-style recorders, was trying to emphasize guaranteed performance and credibility in the field of business machines by making a faithful reproduction of the Magnecorder PT-6. On the other

hand, while Totsuko adhered to the basic principles, it added some of its own original technology.

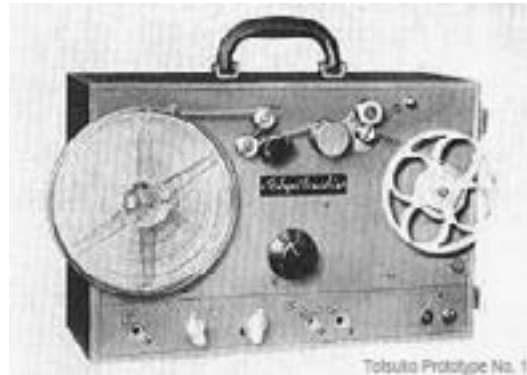

Fig. 4.10. Totsuko Prototype No. 1⁽¹⁰⁾



Fig. 4.11. Denon Prototype No. 1⁽¹¹⁾



Fig. 4.12. PT-11 Totsuko⁽¹²⁾



Fig. 4.13. PT-12 Denon⁽¹³⁾

4.3.2 The Creation of Prototype No. 1 by Totsuko

From the outset, researchers at Tokyo Tsushin Kogyo were very interested in magnetic recording and had studied systems such as the steel wire recorder. Coming into contact with the tape recorder through the NHK, the researchers were convinced of the potential of this new product and concentrated their efforts on developing it. Despite the extreme scarcity of reference material, Totsuko showed incredible manoeuvrability for a start-up company headed by engineers, repeating a number of designs and prototypes in a short space of time. It seems the company was also examining and investigating the principles of magnetic recording, while its procurement of the purportedly indispensable “high frequency bias patent” from Anritsu indicates that it was preparing to ensure the superiority of its products through its unique technological developments. Having abandoned the early steel wire recorders in favour of the tape recorder in its work on magnetic recording, Totsuko worked on its own developments in spite of various hardships. While its first prototype was for the NHK, as mentioned in the preceding paragraph, the development of products for business use definitely contributed greatly to the company’s accumulation of technology. Although the scarcity of parts and materials and the lack of information and technology following the war meant that new product development was rife with difficulties, Totsuko finally released the “G” in 1950, the first domestically-produced tape recorder. At ¥160,000, it was very highly priced. Although tape was also being developed and marketed, it was still the rudimentary paper-based tape. The physical properties of this tape, such as its smoothness, were still underdeveloped, which directly affected the recording and playback functions (Fig. 4.17).

A major obstacle to Totsuko building a tape recorder was the lack of appropriate parts. In particular, the driving motor had to rotate at a constant speed; it had to be silent (a matter of course for sound equipment); it had to produce a certain level of torque. These criteria could not be met with the motors from general electrical goods, such as fans, so the company asked Denon for the use of its hysteresis synchronous motor developed for use in disc-style recorders.

The company also had much difficulty finding a good rubber material to use for the power transmission unit idler and in other parts. Totsuko built up a diverse wealth of knowledge to improve the rubber belts and idlers, which later proved very useful in improving the performance of the Sony tape recorder, ensuring its predominance.

Another major challenge was developing the magnetic tape. The researchers understood that coating a base material with magnetic powder would produce a tape that could be used for recording, but, with very little in the way of reference material, they were blindly guessing as to what they could

use, both for the base material and for the powder coating. With the idea of simply proving the tape was magnetised, researchers ground cylindrical OP magnets into powder in a mortar and tried coating this onto a suitable paper material with a paste made from boiled rice. This experimental tape produced only noise. After various experiments, the researchers concluded that the ground-up magnets were too strong and that they should use a weaker magnet for recording. The use of powdered OP magnets as a magnetic substance was the same method used for the later metal tapes, but perhaps the level of technology at the time meant that the heads were not able to magnetise a highly coercive magnetic substance. The Totsuko research team searched through various sources of literature and found that if a substance called ferric oxalate is oxidised by burning, it becomes ferric oxide. Despite the lack of materials, they managed to acquire a ferric oxalate reagent and immediately set about heating it in a frying pan. The yellow ferric oxalate turned brown and then black; by observing the colour and taking it off the heat at the appropriate time, they were able to produce ferric oxide powder without any problem. To coat this powder onto the base material, they started out by using a spray gun, but this wasted a lot of the powder. Through trial and error, they ended up creating a prototype by applying the powder with a brush. They made repeated recording experiments on a primitive experimental recording device made from a pair of 78 RPM record turntables. They improved the magnetic substance and made various analyses of different choices of base material, but at that time there was no paper or plastic in Japan suitable for use as magnetic tape. They had no choice but to leave it to a paper expert and enlisted the help of Honshu Paper Co., Ltd., which showed a great deal of interest in the development of the new product, as it could potentially supply the base material for the paper tape (Figs. 4.14, 4.15). Following these developments on the magnetic tape and the machine itself, the “G”, Japan’s first tape recorder, was released in 1950.



Fig. 4.14. Tools used for the magnetic tape prototype (replicas)



Fig. 4.15. Prototype tape (1949)



Fig. 4.16. The Totsuko G, Japan's first domestically-produced tape recorder (1950) (14)



Fig. 4.17. Early "Soni-Tape" made by Totsuko (1950) (15)

4.3.3 Marketing Tape Recorder No. 1

Totsuko started marketing the G under the trademark "Tapecorder". Although customers were interested in the novelty of it, it was not readily accepted as a general household item, as it was expensive, big and clumsy, with no obvious usefulness. It was mainly used by public organisations, such as for recording courthouse proceedings. This was what had been foreseen, with even the letter G standing for "government". Totsuko started out marketing in the belief that the popularity of this ground-breaking product would also spread to household use as well. However, although there was some interest in the product, this interest did not really translate into sales. Totsuko reviewed its rather optimistic policy of "if we build a good machine, it will sell" and focused its attention on raising public awareness and advertising the tape recorder, creating a manual to explain the uses and benefits of its top tape recorder and redoubling its sales activities (Fig. 4.18). The company also continued to

develop the product to try to lower the price and increase its ease of use. With technology, patent strategies and marketing as its weapons of choice in the popularity stakes, Totsuko was laying the groundwork for it to become Japan's leading tape recorder manufacturer.



Fig. 4.18. Totsuko tape recorder manual

4.3.4 Totsuko and the AC Bias Patent

As mentioned in Section 3.6, AC bias was discovered by chance in the 1920s during research on magnetic recording, but it was not until the late 1930s that research began in earnest throughout the world on how to improve the performance of magnetic recording. This coincided exactly with the start of the Second World War. Since recording technology had definite useful military applications, such as broadcasting and voice recording, the exchange of technology between countries was stopped until after the war. After Germany's defeat, the Magnetophon – the most advanced technology of the day – was taken and studied in detail by the victors. As a result of the ensuing rapid technology transfer, better, more modern tape recorders were developed and put to use. AC bias came to be recognised as an indispensable piece of technology for high quality recording and playback.

Totsuko began developing the tape recorder in Japan after the war. As well as making its own tape, it also set about carefully examining relevant patents on AC bias, having found that AC bias was necessary in order to be able to commercialise the tape recorder. The patent for AC bias in Japan had come about as the result of research by Kenzo Nagai of Tohoku University and Teiji Igarashi, one of Nagai's assistants who had continued the research at Anritsu Electric. The patent rights were held by Anritsu (Fig. 4.19). After negotiating with Anritsu, Totsuko took over the patent rights for AC bias in October 1949. As this was a huge investment for Totsuko at the time, the company bought the patent jointly with NEC. The Nagai Patent had been granted in Japan in 1940. Although a US patent had also been applied for, the procedures had been interrupted by the war. In the meantime, the Camras Patent had been established as the patent for AC bias in every other country except Japan.

【Nagai Patent】

Teiji Igarashi, Makoto Ishikawa, Keizo Nagai
A Magnetic Recording System Using AC for Bias
Patent No. 136997; applied for in March 1938;
granted in June 1940.

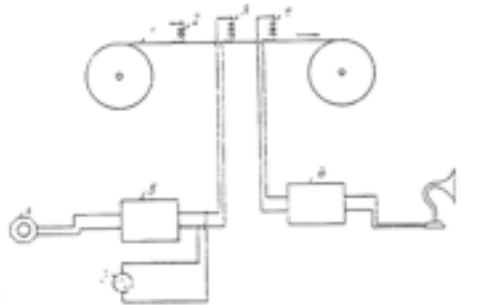

- | | |
|---------------------------------|--------------------------------------|
| 1. Recording medium | 5. Recording amplifier |
| 2. Demagnetisation/erasure coil | 6. High frequency source for biasing |
| 3. Recording coil | 7. Playback coil |
| 4. Microphone | 8. Playback amplifier |

Fig. 4.19. Partial drawing from the “Nagai Patent” on AC bias ⁽¹⁶⁾

4.3.5 Dispute over the AC Bias Patent

The domestic Japanese tape recorder market developed rapidly from the launch of the G in 1950. The AC bias patent proved to be a major weapon for Totsuko to keep other companies out of the marketplace, enabling the company to hold on to its high market share in tape recorder sales. Around this time, the US trading company Balcom began large-scale import and sale of US-made tape recorders in Japan. Totsuko and NEC complained that this was an infringement of their AC bias patent rights and repeatedly issued Balcom with requests to either pay royalties or stop selling. Balcom repeatedly ignored them, so Totsuko presented its case to Tokyo District Court in September 1952. This turned into a major case for Balcom, involving even the GHQ, but Totsuko eventually won the case. During the course of the proceedings, the US patent holder, Armour Research Foundation, came to Totsuko’s attention. Thinking that its exports might be affected, Totsuko reconciled with Armour and the two entered into an agreement of mutual technological assistance.

Totsuko stood firm on patent permission with regard to Japanese manufacturers as well. In 1954, Akai Electric Company launched a tape recorder kit featuring a “new AC bias method”, which ingeniously incorporated a bias circuit (Fig. 4.20). Totsuko immediately objected that this was a patent infringement, but Akai Electric denied this as it “did not violate the Nagai Patent”. Although the matter went to court, Totsuko decided to reach a settlement, in light of its isolation in the industry as well as other circumstances. Nevertheless, fierce competition continued in product development.



Fig. 4.20. Akai AT-1 tape mechanism ⁽¹⁷⁾

With the Nagai Patent licence due to expire in 1955, many manufacturers, including major electric companies, were anticipating getting involved in the tape recorder industry. However, the patent licence was extended for another five years on the grounds that the patent was not able to be put to use during the Pacific War. A number of companies that had been making preparations to enter the industry clearly opposed Totsuko and the Ministry of International Trade and Industry. Although Totsuko continued to refuse to licence the patent rights, by 1958 the manufacturing latecomers were granted consent to use the Nagai Patent. Fierce competition ensued in the development and marketing of new products, and Japan’s tape recorder industry was making tremendous leaps forward.

References

- 1) Abe, Yoshiharu. “Tēpu Rokuon-ki Monogatari Sono 10 [The Story of the Tape Recorder 10]”, JAS Journal 2005, Vol. 45, Nos. 8 & 9.
- 2) Abe, Yoshiharu. “Tēpu Rokuon-ki Monogatari Sono 5 [The Story of the Tape Recorder 5]”, JAS Journal 2005, Vol. 45, No. 1.
- 3) Mori, Yoshihisa, et. al. Onkyō-Gijutsu-Shi [History of Sound Recording], Tokyo University of the Arts Press, March 2011, p. 81.
- 4) Abe, Yoshiharu. “Tēpu Rokuon-ki Monogatari Sono 8 [The Story of the Tape Recorder 8]”, JAS Journal 2005, Vol. 45, Nos. 5 & 6.
- 5) Abe, Yoshiharu. “Tēpu Rokuon-ki Monogatari Sono 24 [The Story of the Tape Recorder 24]”, JAS Journal 2007, Vol. 47, No. 4.
- 6) Abe, Yoshiharu. “Tēpu Rokuon-ki Monogatari Sono 25 [The Story of the Tape Recorder 25]”, JAS Journal 2007, Vol. 47, Nos. 5 & 6.

- 7) Provided by Mori, Yoshihisa.
- 8) Abe, Yoshiharu. "Tēpu Rokuon-ki Monogatari Sono 28 [The Story of the Tape Recorder 28]", JAS Journal 2007, Vol. 47, No. 10.
- 9) Abe, Yoshiharu. "Tēpu Rokuon-ki Monogatari Sono 36 [The Story of the Tape Recorder 36]", JAS Journal 2008, Vol. 48, No. 10.
- 10) Provided by Sony Corporation.
- 11) Abe, Yoshiharu. "Tēpu Rokuon-ki Monogatari Sono 36 [The Story of the Tape Recorder 36]", JAS Journal 2008, Vol. 48, No. 10.
- 12) Abe, Yoshiharu. "Tēpu Rokuon-ki Monogatari Sono 37 [The Story of the Tape Recorder 37]", JAS Journal 2008, Vol. 48, Nos. 11 & 12.
- 13) Ibid.
- 14), 15) Provided by Sony Corporation.
- 16) Abe, Yoshiharu. "Tēpu Rokuon-ki Monogatari Sono 32 [The Story of the Tape Recorder 32]", JAS Journal 2008, Vol. 48, No. 4.
- 17) Abe, Yoshiharu. "Tēpu Rokuon-ki Monogatari Sono 41 [The Story of the Tape Recorder 41]", JAS Journal 2009, Vol. 49, Nos. 5 & 6.

5 | Development of Domestically-Produced Tape Recorders

5.1 The Popular-Model Tape Recorder

Having completed the G, the first domestically-produced tape recorder, in 1950, Totsuko launched the popular-model H (Fig. 5.1) in 1951, aimed at popularising the tape recorder. At ¥84,000, it was around half the price of the G. With a simple mechanical configuration of a single motor and two heads, it was also ingeniously designed to be easier to use, such as having a single knob to switch the tape operation and amplifier between recording and playback. The entire machine was stored in a trunk-like case, which showed that some consideration for household use had been incorporated into its design. In fact, the H was the first model for which Totsuko employed an industrial designer. In 1952, a year after the H, Totsuko launched the even lower-priced P (¥75,000) (Fig. 5.2). The main customers of both the H and the P were elementary and junior high schools as the machines were still too highly-priced for household use. Although Totsuko redoubled its marketing through advertising and public

awareness, the tape recorder remained a largely unknown device in domestic circles. However, its capacity to enrich audio-visual education was being hailed in schools. With its scope of use thus expanded, it was only a matter of time before the school pupils made it commonly known about at home. Totsuko released the R in 1953 at a price of ¥50,000. The following year, it marketed the TC-301, an improved version of this model, as a “small machine for home use”. Although this model was simpler than the H and P models in terms of performance, the tape recorder began to spread through ordinary households in earnest thanks to the onset of mass production and mass marketing of low-priced products around this time.

The speed of product development also increased; in 1954, the TC-302 – the deluxe version of the TC-301 – hit the market at ¥57,000. The following year, in 1955, Totsuko produced a succession of products as the leading tape recorder manufacturer, such as the premium TC-501 (¥84,000) and the two-channel TC-551 (¥135,000), capable of recording in stereo. In 1956, Totsuko released the TC-201 at the drastically-reduced price of ¥38,000, throwing

Table 5.1. Early Totsuko Tape Recorders⁽⁴⁾

Model No.	P-3	TC-301	TC-302	TC-501	TC-551	TC-201	TC-401
Release date and price (¥)	1954(S29).10 69,500	1954(S29).09 49,000	1954(S29).12 57,000	1955(S30).09 84,000	1955(S30).12 135,000	1956(S31).07 38,000	1956(S31).08 65,000
External dimensions (mm)	250×400×300	170×300×300	190×320×300	220×490×360	240×690×430	220×420×335	210×420×330
Weight (kg)	14	8	8.3	15	27	12.3	14
Maximum reel (in)	7	5	←	7	←	←	←
Tape speed (cm/s)	19, 9.5	9.5	←	19, 9.5	←	←	←
Heads (no.)	2	←	←	←	←	←	←
Track	half width	←	←	←	full width erase two-channel · R/P	half width	←
Motors (no.)	2	1	←	←	←	←	←
Speakers (in)	6.5	5	5×7	←	5×7 (x2)	4×6	5×7
Microphone (ohms)	10k	←	←	←	×2	10k	←
Frequency response (19 cm/s) (9.5cm/s)	100~7,500Hz	150~5,000Hz	←	50~10,000Hz 100~6,000Hz	70~10,000Hz ←	150~7,000Hz 200~4,000Hz	50~10,000Hz 100~6,000Hz
SN ratio (dB)	40	40	40	50	50	40	45
Wow-and-flutter (%)	0.5	0.5	0.5	0.25	0.25	0.3	0.25
Bias (kHz)	30	←	←	50	←	30	50
Valves	6AU6×2, 42.80	6AU6×2, 6AR5 6×4	6AU6×2, 6AQ5 6×4, 6E5M	6AU6×2, 12AU7 6 A R 5 × 2 , 5GK4 6E5M	6AU6×2, 12AU7×2 6AQ5×2, 6AR5 6E5M×2, 5Y3GT	6AU6×2, 6AR5 6×4	12AT7×2, 6AQ5 6 A R 5 , 5 G K , 6E5
Power source	AC100V	←	←	←	←	←	←
Power consumption (W)	100	60	75	100	140	60	90

the popular-model tape recorder market wide open (Table 5.1). Although Totsuko had achieved success with the tape recorder, it was always watchful of developments among the major manufacturers because of its own relative lack of capital might. It took great care to ensure the predominance of its own products by improving its product development capabilities and exploiting its AC bias patent.

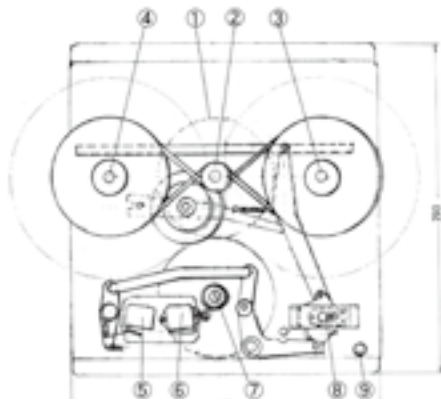

- | | |
|-------------------------|-----------------------------|
| (1) Motor | (6) Recording/playback head |
| (2) Motor axle | (7) Capstan |
| (3) Reel axle (winding) | (8) Switchover camshaft |
| (4) Reel axle (feeding) | (9) Pushbutton |
| (5) Erasing head | |

Fig. 5.1. Totsuko H and an outline of its mechanism (1951) ⁽¹⁾



Fig. 5.2. Totsuko P (1952) ⁽²⁾



Fig. 5.3. TC-551 Stereocorder (1955) ⁽³⁾

5.2 Increase in Manufacturers Entering the Market

While Totsuko obstinately refused permission for other companies to use the Nagai Patent for AC bias, things eventually began to change in the industry, such as Akai's insistence that its "new AC bias method" was not a patent infringement. This occurred around 1955, just when the dispute with Balcom and Armour had reached a conclusion (See Section 4.3.5). Although the regulatory authority, the Ministry of International Trade and Industry, had initially supported Totsuko's position in the dispute with Balcom, it did have some misgivings about obstinate patent right claims in terms of industry development. Totsuko had taken great pains to ensure the predominance of its successful new tape recorder so that it could ensure enough capital to develop the transistor radio. However, Totsuko also recognized that to a degree it had already profited as a founding member of the industry, that competition was an inevitable factor in market expansion, including the export market, and the company was by now confident in its product development ability. In the light of this and other factors, in 1958 Totsuko decided to allow other Japanese manufacturers to use the Nagai Patent, provided that it was through Totsuko and NEC.

This meant that the AC bias method required for analogue tape recorders was freely available for use (albeit with licence fees payable). More than ten companies started manufacturing tape recorders for consumer use, including Matsushita Electric Industrial, Sanyo Electric, Toshiba, Tokyo Electro Acoustic Company (later TEAC) and Yaou Musen (later General). Matsushita began research and development very early on at its central research institute. It took the lead among the latecomer manufacturers, releasing its RQ-201 (Fig. 5.4) in August 1958, right after the patent licence was granted. This set was manufactured by Matsushita Communication Industrial; a number of sets manufactured by Matsushita Electric Industrial proper were released in December the same year.



Fig. 5.4. Matsushita No. 1 RQ-201 (1958)⁽⁵⁾

5.3 Tape Recorders for Use in Education

After the war, the Ministry of Education set about promoting audio-visual education at the request of the GHQ, leasing 16mm projectors to elementary and junior high schools all over the country, among other initiatives. The NHK took charge of audio resources and started full-scale educational broadcasts for schools. This course of events gave a major boost to the popularity of the tape recorder and gave rise to a growing demand for tape recorders in schools. However, the early tape recorders were extremely variegated in terms of operation, specifications and terminology and there was no compatibility whatsoever between them. To rectify this, a motion was drafted by the NHK Science & Research Laboratories and enacted by the Ministry of Education in 1954 to specify the basic standards for the features required in tape recorders for educational use. The main details are given below.

- (1) General Rules: definition of a tape recorder for educational use
- (2) Configuration: Mechanism requirements
- (3) Standards and special conditions
 - 1) Various performance standards and standard tape
 - 2) Level indicator and standard recording level
 - 3) Recording track positioning: compatibility assurance
 - 4) Overall sound characteristics
- (4) Insulation tests and pressure tests
- (5) Product labelling and associated books

Popular-model tape recorders with built-in speakers, produced in Japan in accordance with these standards, went on sale from around 1955. At the same time, a variety of similar tape recorders from the West and other overseas countries were imported and sold domestically (Fig. 5.5). While the tape recorders for educational use (in schools) came down in price, they were quite bulky and seemed very

much like business equipment; the smaller, more portable types were more popular for home use. The machines for school use had standard reel sizes from No. 7 (18cm) to No. 10 (27cm), while the machines for home use ranged from No. 5 (12cm) to No. 7. While a longer recording time was afforded by having as long a length of tape as possible on a reel, the price of the tape was a major factor for home use. To economise on tape consumption, a tape speed of 4.8cm/s was added to the existing standardised speeds of 19cm/s and 9.5cm/s. With the advent of the 1960s, popular models emerged in great numbers at greatly reduced prices. The demand also grew for tape recorders for studying at home (Figs. 5.6, 5.7). The time for great numbers of small-to-medium manufacturers in the industry had ended. The time had come for major manufacturers to take on the tape recorder in earnest, producing far superior machines. There was much competition between the popular models made by major manufacturers. Matsushita released the RQ-303 (Fig. 5.8), which used a dedicated No. 4 reel (10cm) and a tape speed of 4.8cm/s to make it smaller and more lightweight. At ¥10,000, around half the price of other machines in the same class, it was a major hit. In 1958, Tokyo Tsushin Kogyo changed its name to Sony Corporation, with the idea that merging the company name and product name would reinforce the brand name.



Fig. 5.5. TK-9, made by West German company Grundig⁽⁶⁾



Fig. 5.6. Toshiba GT-620 "College Ace" (¥18,800)⁽⁷⁾



Fig. 5.7. Sony TC-111 (¥19,800) (1961)⁽⁸⁾



Fig. 5.8. Matsushita RQ-303 "Mysonic" (¥10,000) (1963)⁽⁹⁾

5.4 Emergence of "Densuke"

In 1946, right after the war, the NHK started broadcasting so-called "man-on-the-street" interviews, run by announcer Shuichi Fujikura. The novelty of these "audience participation programmes", in which the ordinary people became part of the cast, as well as the interviews on current public opinions, made these programmes very popular. At first, the NHK used the disc-style recorder (Fig. 5.9) that had been used in broadcasting since before the war. Although it was portable, it was heavy, susceptible to vibration, the records had to be changed over due to the limited recording time on each disc and the recording level had to be constantly adjusted. These factors would have made it very difficult to operate in the street.

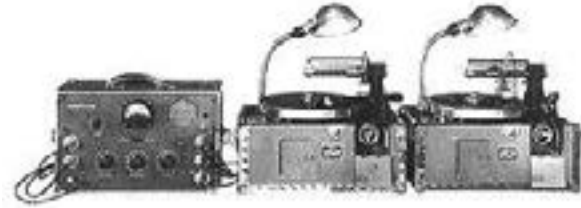

Fig. 5.9. Denon disc-style recorder used in "man-on-the-street" interviews⁽¹⁰⁾



Fig. 5.10. Stancil-Hoffman "Mini-Tape"⁽¹¹⁾

Around this time, portable tape recorders were being introduced from the United States. In 1951, the NHK began to use these for its "man-on-the-street" interviews. The model used was the shoulder-strap-style "Mini-Tape" made by Stancil-Hoffman (Fig. 5.10). Equipped with a No. 5 reel, this machine was capable of two speeds of 38cm/s and 19cm/s. The DC motor rotated in sync with an internal vibrating oscillator (details unknown) as part of a drive system to produce a steady revolution speed. It was a dedicated recording machine, with the built-in valve amplifier only used for basic recording, although a small external amplifier, sold separately, could also be attached for monitoring. When Nobutoshi Kihara of Totsuko heard about this machine, he started investigating similar machines, referring to photographs and other reference materials, without ever having seen the machine itself. In March 1951, he started on a prototype, which he supplied to the NHK in July that year (Fig. 5.11). Despite the fact that he had the Mini-Tape to refer to, it is actually quite remarkable that he developed a working prototype in such a short space of time. It was configured quite simply with a valve amplifier dedicated to recording, a single recording head and no erasing head. Although this meant that the recording tape had to be demagnetised in advance, it was well received as a recording device for professionals, who actually preferred simplification if it ensured reliability. While the tape operation system and drive system resembled those of the Mini-Tape, no suitable

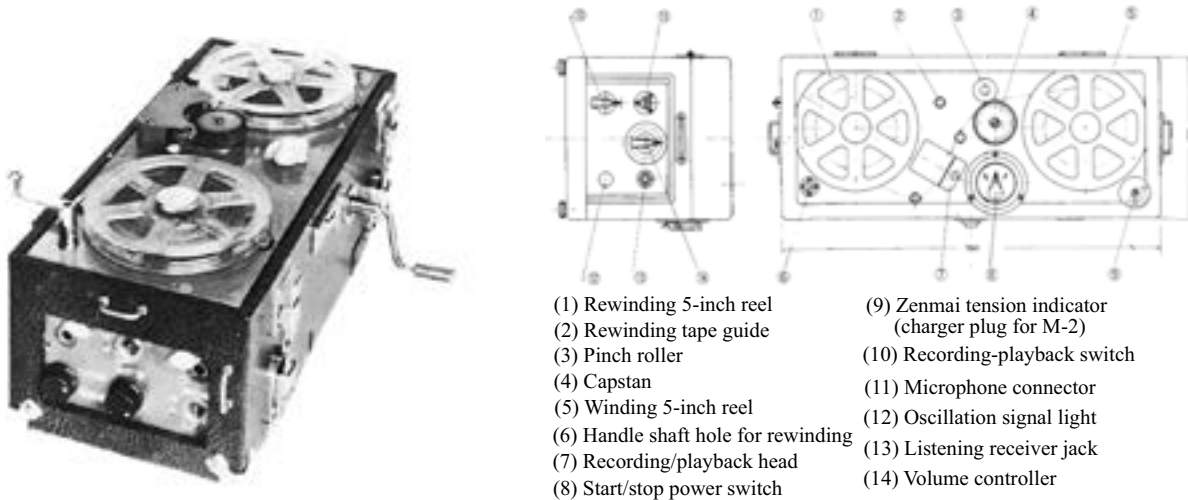

Fig. 5.11. Photograph and exterior diagram of Totsuko M-1 (1951) ⁽¹²⁾

DC motor could be procured domestically in those days. Kihara eventually settled for a hand-wound spring motor for gramophones (a Zenmai motor), made by Nippon Columbia. Fully wound, the spring motor could drive the machine for around four minutes. Ingeniously, Kihara incorporated an additional winding mechanism that enabled a No. 5 reel to operate continuously for 15 minutes.

Having introduced the Totsuko shoulder-strap-style recorder, the NHK was immediately able to boost the manoeuvrability of its “man-on-the-street” interviews, which in turn boosted the popularity of its programmes. Ryuichi Yokoyama turned these “man-on-the-street” interviews into cartoon form with his “Densuke” character that appeared in the Mainichi Shimbun. The Totsuko tape recorder came to be known as the “Densuke”, based on this character, roaming the streets with his tape recorder on his shoulder doing “man-on-the-street” interviews about current events. In the broadcasting industry, this nickname came to be used to refer to outdoor-use recording machines.

Totsuko registered the name Densuke as a trademark, using it as a pet name for its portable tape recorder. Although the name remained in popular use between professionals in the industry, it was soon forgotten in the everyday tape recorder world. However, the name once again gained popularity as the pet name for everyday tape recorders (see Section 6.11) when the “Cassette Densuke” TC-2850SD portable cassette deck (Fig. 5.12) appeared in 1973 along with a boom in live recording. Later, the Open Densuke (Fig. 5.13) and Elcaset Densuke (Fig. 5.14) appeared and the name Densuke became synonymous with the highly-portable tape recorder in the everyday tape recorder world.



Fig. 5.12. Sony TC-2850SD (1973) Cassette Densuke ⁽¹³⁾



Fig. 5.13. Sony TC-5550-2 (1974) Open Densuke ⁽¹⁴⁾



Fig. 5.14. Sony EL-D8 (1977) Elcaset Densuke ⁽¹⁵⁾

5.5 Ultra-Small Magnetic Recorders

With its success in the domestic production of a shoulder-strap-style tape recorder, which had been adopted by the NHK as well as other commercial broadcasters, Totsuko set about researching and developing an even smaller magnetic recorder. An ultra-small magnetic recorder called the Minifon had been developed and marketed in Germany in 1952 (Fig. 5.15). This was a wire recorder with 0.05mm steel wire as its recording medium and its minute mechanism contained in a tiny casing. It was configured with precise detail, with forethought given to ease of use and stable operation. It could record, playback and rewind; appropriate tension on the wire at all times prevented it from breaking or jamming. In 1955, a magnetic recorder called the “Midgetape” (Fig. 5.16) appeared in the United States, based on the concept of the Minifon. This was a uniquely-configured, ultra-small tape recorder that used a cartridge-style tape with two tiny reels in a casing.



Fig. 5.15. External and internal views of the Minifon (1952) ⁽¹⁶⁾



Fig. 5.16. The Midgetape and its special tape cartridge (1955) ⁽¹⁷⁾

The Totsuko SA-2 Babycorder (Fig. 5.17) hit the market in 1957, probably based on these models. With the aim of becoming ultra-small and lightweight yet maintaining performance, it incorporated a transistor amplifier. Equipped with a cartridge like the Midgetape and operated with ten AA batteries, it was small in size and easy to use. More mobile than the M model, it was supplied in great numbers to broadcasters and other organisations. However, it disappeared off the market within a few years, as it was too highly priced at over ¥100,000 to become popular in general use. Nevertheless, Totsuko’s commitment to developing smaller, lightweight models became typical of later development trends in the consumer electronics industry.

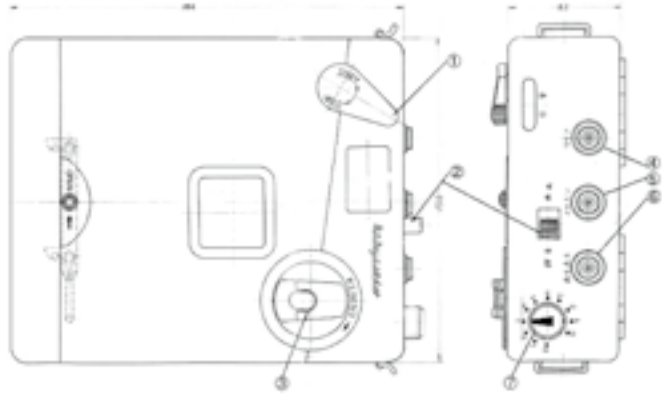

Fig. 5.17. Sony SA-2 "Babycorder" (1957)⁽¹⁸⁾

5.6 Battery-Operated Tape Recorders

Around 1959-1960, export manufacturers began to make large quantities of "reel-driven" battery-operated tape recorders, in which the tape was driven only by the rotation of the reel. While these could be regarded as copies of a reel-driven tape recorder made by a German manufacturer in 1958, they were mainly made for export to the United States, being quite simple in construction and relatively easy to manufacture. The reel-driven machines had no capstan to move the tape at a constant speed; they simply recorded by rotating the winding reel at a fixed revolution and thus could be built with a very simple mechanism. However, since the tape speed changed from the start of the tape to the end of the tape, recordings could only be played back on the machine on which they were recorded (self-recording) and were not compatible with any other machine for playback. The variation in recording and playback performance from the start of the tape to the end of the tape also meant that it was difficult to develop this into a high-quality recorder. These tape recorders never appeared on the Japanese domestic market. With their simplified performance and low price, many of them were little more than toys.

Meanwhile, proper battery-operated, capstan-driven, portable tape recorders gradually grew in number. By the mid-1960s, tape recorders were well-established in the export market, although the simplistic, reel-driven models had disappeared. This led Japanese manufacturers to work on the compact cassette style tape recorder. Sony launched its battery operated, portable tape recorders, such as the performance-enhanced, capstan-driven SA-2 Babycorder for business use and the tiny TC-902 for personal use, but they did not always meet with success.

Matsushita Electric entered the tape recorder market in 1958,

but could achieve no definitive advantage over industry leader Sony (Totsuko). Matsushita determined to establish its own place in the market, setting its sights on the battery-operated tape recorder, which Sony had not yet mastered. In those days, the greatest obstacle to battery operation was the lack of good quality, small-scale DC motors. With the help of its battery and device departments, Matsushita set to work on basic component development, such as simplifying mechanisms and improving motor efficiency. In December 1960, it completed the RQ-112 (¥37,500). The following year in 1961, it launched the improved RQ-114 model, laying the foundation for battery operated, portable tape recorders and leading to the best-selling RQ-102 in 1965. Motivated by the developments among the latecomer manufacturers, Sony launched the TC-800 (¥36,000) in 1966 (Fig. 5.19), with a built-in, direct drive servo motor. Development competition grew increasingly fierce among the major manufacturers, ushering in the compact cassette era.



Fig. 5.18. Sony TC-902 (1959)⁽¹⁹⁾



Fig. 5.19. Sony TC-800 (1966)⁽²⁰⁾

5.7 Development in Function and Performance

5.7.1 Stereo Conversion

Tape recorders enable multiple-track recording on the same tape. In principle, it is very simple to create the stereo effect. While disc records were the mainstream medium of the music industry, the question of how to record (cut) and play back a single sound as two signals presented a very difficult problem. In 1931, British electronics engineer Alan Blumlein patented the idea of a 45/45 system to record separate signals from the left and right walls of the groove in a record, although this was not put into practical use until after LP records appeared in 1958.

While magnetic stereo recording experiments had been carried out in 1939 on steel wire recorders, the two-track recorder released by the US company Magnecord in 1949 was the first tape recorder to incorporate stereo sound. The head placement was the so-called staggered type (Fig. 5.20), where the two channels are set slightly apart from each other. Given the head manufacturing technology available at the time, it was difficult to achieve the manufacturing precision required to have two tracks on one head; there was no choice but to have a separate head for each track. By the late 1950s, many stereo tape recorders were being sold in the United States, including machines for home use. Rapid progress was made on the speaker-less “stereo tape deck”, as it could be used in the home in conjunction with other audio equipment. It was easy to use because it worked on the same machine as a record player and the cost was relative to the improvement in performance. Advancements were also made on head technology, and the stacked arrangement (Fig. 5.21) soon replaced the staggered. Although stereo tape records (music tapes) grew in popularity as the stereo playback media of choice in the home, they quickly lost their top spot in the market when the cheaper stereo LP records went on sale. Stereo tape recorders had a slow start in Japan, although

when stereo FM broadcasts started in earnest around 1970, tape decks grew tremendously in popularity as a means for recording these broadcasts.

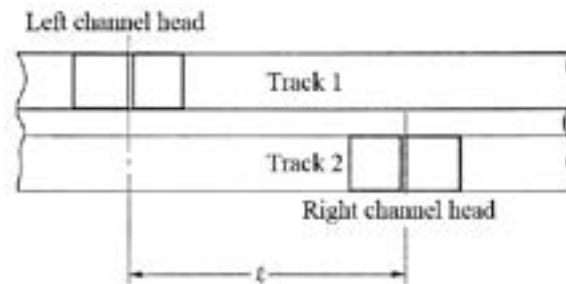

Fig. 5.20. Staggered head placement⁽²¹⁾

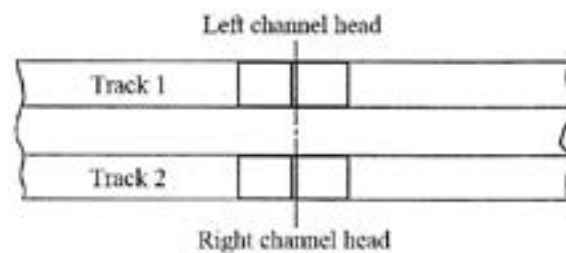

Fig. 5.21. Stacked head placement⁽²²⁾

5.7.2 Transistors

To begin with, all tape recorder amplifier units used valves, but with the increasing use of the transistors in electronic equipment, researchers began examining their application in tape recorders. In 1959, Hyfax incorporated transistors into its TR-100S stereo tape deck; however, it went off the market almost immediately as the product was somewhat imperfect: the transistor is a difficult component to get right, producing a lot of unwanted noise and causing the amplifier to behave erratically.

Accordingly, the first proper transistor tape recorder in Japan was the TC-777 (Fig. 5.22) produced by Sony in 1961. Although it was monophonic, the TC-777 was a semi-professional, high quality machine with three heads, three motors and electronic operating buttons. It also had built-in power amplifiers and speakers. It was very popular with its extremely high cost performance, and was outstanding in design as well. Its successor, released in 1964, was a stereo tape deck. From then on, there were rapid advancements in the use of transistors in tape recorders and this became a feature of battery-operated, small-scale compact cassette players.



Fig. 5.22. Sony TC-777 (1961)⁽²³⁾

References

- 1) Abe, Yoshiharu. “Tēpu Rokuon-ki Monogatari Sono 41 [The Story of the Tape Recorder 41]”, JAS Journal 2009, Vol. 49, Nos. 5 & 6.
- 3) Ibid.
- 4) Ibid.
- 6) Abe, Yoshiharu. “Tēpu Rokuon-ki Monogatari Sono 27 [The Story of the Tape Recorder 27]”, JAS Journal 2007, Vol. 47, Nos. 8 & 9.
- 7) 50 Years of Audio. Japan Audio Society Publishing, December 1986, p. 476.
- 10) Abe, Yoshiharu. “Tēpu Rokuon-ki Monogatari Sono 39 [The Story of the Tape Recorder 39]”, JAS Journal 2009, Vol. 49, Nos. 2 & 3.
- 11) Ibid.
- 12) Ibid.
- 16) Abe, Yoshiharu. “Tēpu Rokuon-ki Monogatari Sono 45 [The Story of the Tape Recorder 45]”, JAS Journal 2009, Vol. 49, Nos. 11 & 12.
- 17) Ibid.
- 21) 50 Years of Audio. Japan Audio Society Publishing, December 1986, p. 481.
- 22) Ibid.
- 2), 8), 13), 14), 15), 18), 19), 20), 23) Provided by Sony Corporation.
- 5), 9) Provided by Panasonic Corporation.

6 | Emergence of Cartridge-Type Tape Recorders

6.1 Characteristics of the Open-Reel Tape Recorder

The first proper tape recorders began to appear after the war and rapidly replaced the disc-style recorder. By the 1960s, tape recorders were the first choice of recorders from business use to home use. They became indispensable equipment for broadcasters and recording studios and were well-received in other industries, such as music production, where multi-track recording enabled new musical works to be created. The superior features of the tape recorder mesmerised many audiophiles and it now became a popular piece of household audio equipment. However, from the beginning, these tape recorders were all “open-reel” machines that needed reels of tape to work. In order to maintain high quality, open-reel tape recorders had to have a high tape speed, which used up a lot of tape. This meant that the reels and the overall machine had to be quite large in size. Of course, there were smaller machines, but many of them had to compromise on features or recording time. The fact that these tape recorders needed reels of tape to work meant they were difficult for the average person to use. People ran into various difficulties, such as the tape on the reels being damaged by careless treatment, or the tape coming unwound and jamming. Although studies on using the tape in a cartridge (case) as a way to overcome these shortcomings had been made quite early on after the war, nothing practical had eventuated from these studies.

6.2 RCA Cartridge

Stereo tape decks came into popular household use as a means of stereo playback from around the mid-1950s in the United States. Quite a number of music tapes went on the market around this time as well. Although the 45/45 stereo LP record became quite popular after it hit the market in 1958, the stereo tape recorder remained the main item of household audio equipment in the United States until the mid-1960s. Given the popularity of music tapes, RCA set about researching cartridge-style tape recorders quite early on. In 1958, RCA Victor announced its cartridge-style tape (Fig. 6.1) and put around 150 kinds of music tapes on sale along with the tape recorder. Measuring 184×120×12mm, the cartridges were larger than the compact cassettes that would later emerge. The tape was 6.3mm in width, the same as that of the open-reel machines, while being 25µm thin and 600ft (around 180m) in length. The tape ran at a speed of 9.5cm/s; the four-track, two-channel stereo setup could record or play back for 32 minutes at a time. However, it was

difficult to maintain precision in the cartridge itself when it went into mass production. It required a narrow head gap to achieve the desired level of recording/playback performance, which was impossible to achieve with the manufacturing and components technology available at the time. This made it difficult to ensure product quality. Manufacturers were not willing to come on board and the attempt ended in failure.



Fig. 6.1. RCA cartridge ⁽¹⁾
120 x 184 x 12 mm

6.3 Car Stereos and the Endless Cartridge

As audio equipment became more popular for home use in the United States, it spurred a demand for the development of in-vehicle audio equipment, or the car stereo. In-vehicle entertainment started out with car radios and rapidly gained momentum in response to user demand, with innovations such as car audio equipment using disc records (Fig. 6.2). Development also began on cartridge-style tape recorders intended for car audio. Vibration is a major issue in vehicles and disc players were never very popular in cars, as this was a very difficult problem to overcome. However, vibration resistance is one of the strengths of tape recorders, making this issue relatively easy to overcome. As well as needing to be smaller than the existing models, tape recorders for car stereos could only be cartridge-type machines, to ensure operability and to store the tape safely.

The Fidelipac cartridge went on sale in the United States in 1962 and became very popular for in-vehicle use. These cartridges measured 102x133x24mm and held a 6.3mm tape in an endless loop. With a four-track stereo system (two stereo programmes) and a tape speed of 9.5cm/s, these tapes could play for ten minutes (Fig. 6.3).

In 1965, US company Learjet put out an eight-track cartridge that was around the same size as the Fidelipac (102x136x22mm) (Figs. 6.4, 6.5). The tape width and speed were also the same as the Fidelipac, but with eight tracks (four stereo programmes) it could play for around 60 minutes. The

eight-track was a success and it soon beat all competition to become the standard car stereo. In a short space of time, it had spread throughout the United States. The early car stereos in Japan also used the eight-track cartridges. These cartridges became the popular choice of car stereo tape, becoming the forerunner of later developments in the CD/laser disc karaoke machine.



Fig. 6.2. In-vehicle record player (XLP Record)⁽²⁾



Fig. 6.3. Fidelipac cartridge (1962)⁽³⁾
102 x 133 x 24 mm four-track/two channel

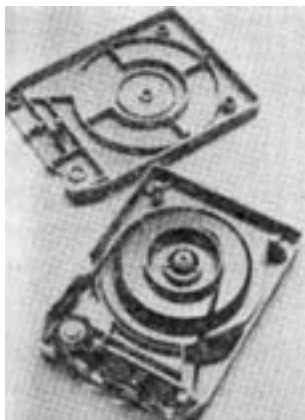

Fig. 6.4. Learjet eight-track cartridge (1965)⁽⁴⁾
102 x 136 x 22mm eight-track/two-channel

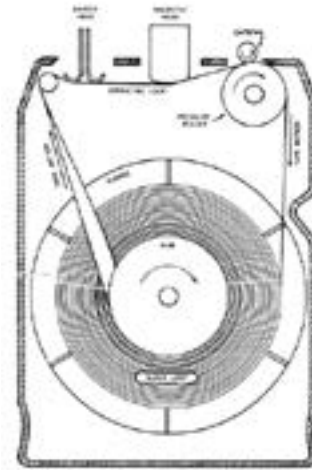

Fig. 6.5. Structural diagram of an eight-track cartridge⁽⁵⁾

6.4 Emergence of the Compact Cassette

As the car stereo was growing in popularity and the endless-loop cartridge tape was emerging onto the scene in the United States, a twin-hub cartridge tape was attracting attention in Europe: the “Compact Cassette” developed by the Dutch company, Philips. While RCA, mentioned in Section 6.2, had planned to release its own cartridge design to European tape recorder manufacturers in the hope that it would be popularised in Europe as well, no manufacturers were willing to take it on and the RCA cartridge ended in failure. While the company later worked with European manufacturers to make the cartridge better and smaller, resulting in a new style of cartridge, there was disagreement among the companies, which ended in a struggle for supremacy between the following two types of cartridge (Fig. 6.6).

(1) DC (Double Cassette) International Type

Promoted by: Grundig, Telefunken, Blaupunkt (all German companies)

Released: 1963

(2) Compact Cassette Type

Promoted by: Philips (the Netherlands)

Released: 1962 test sale, 1964 full sale

Both cartridge types were smaller than the RCA cartridge, while the tape width, tape speed and other characteristics were based on a completely new, easy-to-use format completely unrelated to the open reel specifications. The Compact Cassette format eventually won out for the reasons below, although a major reason was Philips’ decision to make its patent freely available in order to popularise it.

Success factors for the Compact Cassette format:

- (1) Smaller cartridge size

- (2) Twin hub structure prevented tape jamming and improved tape running
- (3) (The potential for) superior sound quality / performance
- (4) Careful development approach of provisional sales and getting feedback from the market
- (5) Free patent licence

strict standards in place and incorporating all kinds of innovations within the scope of these standards to produce a superior product not only gave users greater convenience and greater confidence in the product and format, but also prevented innovative technology from being short-lived in the marketplace. This was the perfect way for Japanese manufacturers to demonstrate their talents.

It seems that Philips did not originally set out to make the patent freely available, but it eventually switched to its free-patent policy while competing with the opposing DC International format. Around 1963, Grundig proposed to Sony that they jointly promote the DC International format; soon afterwards, Philips made the same proposal regarding the Compact Cassette format. Philips also approached other Japanese companies in regard to adopting the Compact Cassette format, proposing a royalty fee of ¥25 per piece. When Sony seemed inclined to decline, Philips pressed for a contract at a drastically reduced price. Sony flatly refused and Philips finally announced it would offer the licence to Sony for free. Then, in the light of antitrust laws and its business credibility, Philips made the bold move in 1965 of making the basic patent available to all manufacturers worldwide rather than just to Sony. One of the conditions of this was that manufacturers should “strictly adhere to the standards and strictly maintain compatibility”. This served as a huge boost to the spread and development of the Compact Cassette.

The Compact Cassette format was strongly focused on compatibility. Unlike the open-reel system, it was compatible with mono and stereo (Fig. 6.7). The system of putting

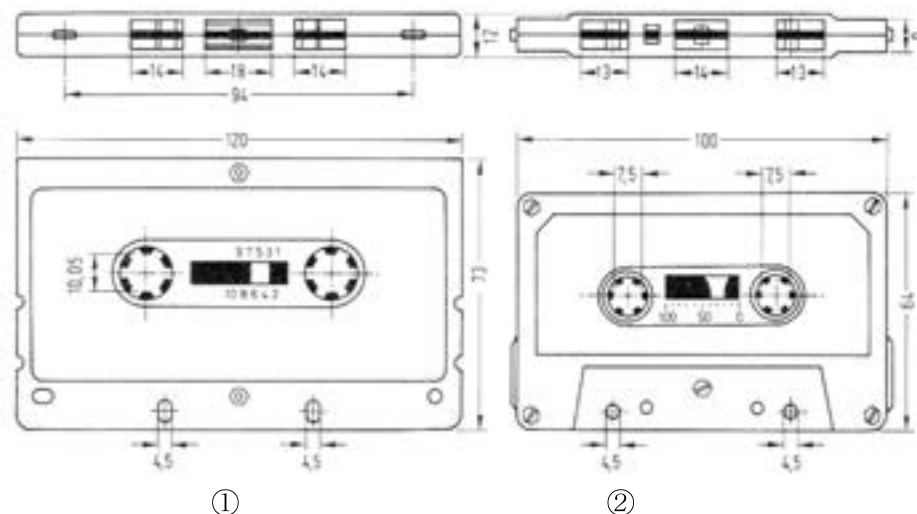

Fig. 6.6. (1) DC International and (2) Compact Cassette⁽⁶⁾

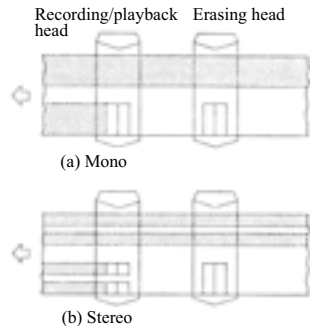

Fig. 6.7. Compact Cassette track arrangement⁽⁷⁾

6.5 Technological Developments for the Compact Cassette

The Compact Cassette started out as a monophonic note-taking machine with none of the so-called Hi-Fi capabilities for music playing. When Philips brought it onto the market, the company first made a cautious test sale. While this was definitely successful in terms of laying the foundation for the Compact Cassette system, a few key technologies needed to be developed before it could achieve Hi-Fi capabilities with a slow tape speed of 4.76cm/s and a narrow track width of 0.6mm (one stereo track) and become a mainstream tape recorder for music use. For the tape recorder to produce a sound that was closer to the original, it needed a wide frequency response and a guaranteed dynamic range. This became the target of technological development. In terms of the mechanical performance of the running of the tape, it was also very important to have a steady tape speed and to ensure the head stayed in constant contact with the tape without disturbing it. Open-reel machines achieved better performance by increasing the tape speed and broadening the track width. Relatively free from structural design constraints, it was also easy to improve the running performance of the tape on these systems. Although there were some disadvantages with the open-reel machines, such as their bulkiness and high tape consumption, they were the best option in terms of consistent sound quality. Since the Compact Cassette used far less tape than the open-reel systems, as shown in Table 6.1, and had to adhere to certain standards, there could be no change in tape speed or track width. Consequently, to improve its basic recording performance, improvements had to be made to the magnetic substance on the tape and to the head that played the tape. It was also difficult to ensure the accuracy of the tape operation, since the tape system was contained within the confines of the cartridge and the mechanism itself was tiny. Consequently, another major challenge was to develop and improve the precision of the motor and parts. The major technology challenges within these various constraints are given below on a priority basis.

- Tape: Developing a high-quality magnetic substance better than ferric oxide
- Heads: Developing a core material to make the best use of the magnetic substance in the tape; achieving a stable, narrow gap
- Noise reduction: Developing and (de facto) standardising a system with high cost performance
- Servo technology: Achieving precise rotation control with a small-scale DC motor / low-speed rotating motor
- Improved mechanical precision: Ensuring intensity and accuracy with small-scale parts; progressively introducing new materials

Table 6.1. Basic Parameter Comparison of the Open-Reel System and the Compact Cassette

	Tape Speed (cm/s)	Track Width (mm)
Open Reel	9.5 – 38.0	1.0 (four stereo tracks) 2.0 (two stereo tracks)
Compact Cassette	4.76	0.6 (stereo)

6.6 Success as an International Standard

Tape recorders had their beginnings after the war in the form of open-reel machines. As well as having good sound quality and long-playing capabilities, these were easier to use than the disc-style recorders and soon gained popularity as the recorder of choice. As they reduced in price, they became popular audio equipment for home use, with music tapes also becoming available on the market. However, the open-reel machines were bulky and somewhat cumbersome to use, which prevented their popularity from spreading even further. As discussed in the previous section, a number of ideas were put forward in the 1960s to encase the tape in a cartridge. This is when the Compact Cassette hit the market as the more orthodox of these cartridges. Although at first it fought with other formats for dominance, the momentous decision by Philips to licence its patent free of charge to manufacturers worldwide succeeded in making it the de facto international standard very early on. Unifying the format meant that not only endorsed manufacturers but also members of the surrounding industries, such as materials manufacturers and parts manufacturers, could also confidently make development investments into the Compact Cassette format, thereby creating a virtuous cycle of rapid technological enhancement. While the basic small size specifications meant a lower quality product than the open-reel system, the developers focused on improving the limited recording and playback performance by making various essential technological developments with the tape recorder,

such as working on the tape, heads, noise reduction and servo control. By the early 1970s, the cassette deck was a fully-recognised piece of audio equipment. Cassette deck tape recorders had come to be acknowledged as proper magnetic recording machines and not just toys.

6.7 Compact Cassette Tape Recorders in Japan

The Philips EL-3301 cassette recorder was first released in Japan in May 1965, ushering in Japan's Compact Cassette era. The first sales were not made by electronics stores, but rather by the department store chain Mitsukoshi. At ¥27,000, they were quite highly priced, but they seem to have sold out immediately thanks to ingenious PR and choice-goods sales floor management by Mitsukoshi, which at the time had a reputation for sophistication (Fig. 6.8). The following year in April 1966, Matsushita Electric launched the EL-3301T (Fig. 6.9) with Philips as the OEM; in June that year, Aiwa released the first domestically-produced model. By the end of the year, Sony, Sanyo, Columbia, Standard and a number of other companies had launched similar products. By 1967, fierce development and marketing competition had begun, with almost all of the major Japanese audio equipment manufacturers having a Compact Cassette product line-up.



Fig. 6.8. Philips EL-3301 catalogue at the time the product was launched (1965) ⁽⁸⁾



Fig. 6.9. Matsushita EL-3301T (1966) ⁽⁹⁾

6.8 Standardised Cassette Tape Recorders

By the time the Compact Cassette appeared, tape recorders had a diverse range of applications, such as learning tools for studying. Although there had been a lot of competition to develop a high quality tape deck for recording music, everyday tape recorders for home use were battery operated, monophonic devices and, to a certain extent, fairly low priced. While the 3-5" open-reel tape recorders for home use had been fairly well-received on the market, they were big, heavy and difficult to use; the users had to know how to work the machine and mainly tended to be young people such as students. The appearance of the Compact Cassette presented an opportunity to expand the target consumer group to include those who had previously not been considered, such as women and the elderly. This provided a huge boost to the tape recorder market for home use. With the range of target users expanding to include a wider range of ordinary people, the external appearance of the tape recorder inevitably underwent some design changes to make it more appealing; an increasing number of Compact Cassette machines were flat in shape with built-in microphones and piano-key button operation (Figs. 6.10, 6.11). Stereophonic machines that doubled as tape decks appeared in the product lineups alongside the general monophonic machines. Compact Cassette machines were becoming the mainstream tape recorders of choice.



Fig. 6.10. Sony TC-100 (1966)⁽¹⁰⁾
Sony's first Compact Cassette machine



Fig. 6.11. Sony TC-1160 (1968)⁽¹¹⁾
The first machine with an inbuilt electret condenser microphone

6.9 Ultra-Small Handheld Devices

Sony brought out its first Compact Cassette tape recorder, the TC-100, in 1966. Operated by AC mains, battery or car cigarette lighter, its cassette pop-up mechanism, piano key buttons and other features made it easy to use in terms of function. It was quite deep and rectangular in shape, closely resembling the early Philips machines, and was usually only used on a desk. To fully play on the strengths of the Compact Cassette, tape recorders had to be user friendly, with one-hand operation and an input microphone. Of course, they also had to be small, lightweight and battery-operated. In 1968, Sony released the TC-50 (Fig. 6.12), featuring an inbuilt microphone for dictation, one-hand operation and an original shape. This model could be seen as an attempt at downsizing the Compact Cassette player. The operability and mobility afforded by the inbuilt microphone was well-noted; the machine received much attention thanks to its use by the crew aboard the Apollo 10 spaceship (Fig. 6.14). Since the main target markets for this type of small-scale tape recorder were business use, such as for data collection and dictation, and educational use, such as for conversation drills and lessons, it was more important to make the machine smaller, lighter and more operationally reliable than to give it Hi-Fi

capabilities. Since these devices were intended more for DC operation, battery lifespan was also a major issue. Reducing energy consumption was the prime focus for this category of product.

The concept embodied in the TC-50 continued in its successors. It was followed by the TC-1000 (1972), which had various improvements in function and performance, such as an anti-rolling mechanism and auto-shutoff feature, as well as improved operability through its button-type operation. By 1978, the series had developed as far as the TCM-100 (Fig. 6.13), which, complete with a coreless motor, became the mother of the first "Walkman".



Fig. 6.12. Sony TC-50 (1968)⁽¹²⁾



Fig. 6.13. TCM-100 (1978)⁽¹³⁾
"Pressman"



Fig. 6.14. The TC-50 aboard the Apollo

6.10 “Kappa” Book Sized Tape Recorders

Ultra-small, handheld tape recorders such as the TC-50 were often used in business for tasks such as data collection. Proposals were made to design standard home-use tape recorders in such a way as to make them useful for business purposes as well. Developers began focusing on downsizing and especially slimming down these machines, so that as well as being functional, they could be used on a desk or put in a briefcase. A slimmed down tape recorder was the engineer’s dream. Rapid improvements in technology among parts manufacturers in the early 1970s meant higher-precision parts, enabling the design of mechanisms that were thinner than had previously been possible. In 1975, Sony released the ground-breakingly slim TC-1100 (Fig. 6.15), only 29.5mm in thickness. Not only was this model slim, it also had a surface area comparable to that of a “Kappa” book, a well-known style of paperback with a defined size of 11 x 17cm. With this very smart, impressive design, it was a success, with endorsements ranging from business use to home use. The single Compact Cassette tape recorder can be said to have developed from the TC-50 into the handheld headphone stereo, reaching its final form in the slim models such as the TC-1100. For a long time, the TC-1100 series dominated the general tape recorder market for business and home use, bringing out similarly-sized multifunctional devices that incorporated radios, as well as other follow-on models with better designs. Fig. 6.16 shows the mechanism of the TCM-280, one such follow-on model. The design makes much use of stainless steel in various parts such as levers, allowing thinness as well as strength. The slim, brushed DC servomotor uses counter-EMF. The permanent magnet DC erase head reduces electric current consumption, while the standard-sized recording/playback head is of permalloy (Fig. 6.17).



Fig. 6.15. Sony TC-1100 (1975) (14)
The first Kappa book sized device

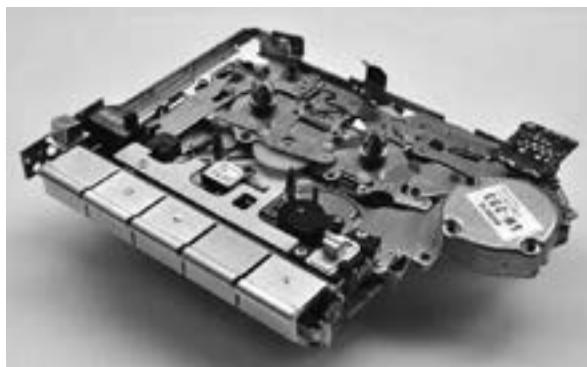

Fig. 6.16. TCM-280 mechanism



Fig. 6.17. TCM-280 erase head, recording/playback head

6.11 Cassette Densuke and the Live Recording Boom

In 1973, eight years after the Compact Cassette appeared in Japan, Sony released the portable TC-2850SD (Fig. 5.12), a Hi-Fi deck. Even though this model was battery-operated and portable, it had all the capabilities of a proper tape recorder, equipped with a high-grade microphone amplifier, a Dolby noise reduction system and a high-quality recording amplifier. Since its functionality and performance were outstanding for a portable Compact Cassette player, it came to be known as the “Cassette Densuke”, inheriting the pet name that had been used for portable, business-use tape recorders. The introduction of this model triggered a “live recording boom”, with a slogan describing it as “no ordinary deck mechanism”. It also played a major part in boosting the confidence of general and business users in the sound quality and potential of the Compact Cassette. Even though the TC-2850SD was a high-performance model, its mechanism was the standard format of the day; the focus had been on higher quality recording and stable performance rather than downsizing it and including an amplifier unit. With the success of this model, a number of other similar high-performance, portable Compact Cassette recorders were produced. Five years later in 1978, Sony released the TC-D5 (Fig. 6.18), combining both small size and high performance. While the “live recording boom” had died away, the TC-

D5's small, sharp-looking design and outstanding basic performance were highly regarded. The model became a long seller, being well received by users serious about sound quality, from high-end amateurs to professionals. However, small-scale, portable tape recorders had one weakness: the rotational accuracy of the capstan, which was the pivotal part of the tape drive. To improve this accuracy and also to prevent the rotation being disturbed by external interference, the TC-D5 incorporated a "disc-drive" driving system. The basic configuration of this system was a small coreless motor in direct contact with a rim-driven flywheel on the capstan spindle, with a frequency generator fitted onto the flywheel to detect rotation. Ingenious details such as the materials used and the contact pressure on the motor pulley and the flywheel allowed the driving force to be transmitted cleanly while preventing the motor from vibrating (Fig. 6.19).



Fig. 6.18. Sony TC-D5 (¥99,800) (1978) ⁽¹⁵⁾

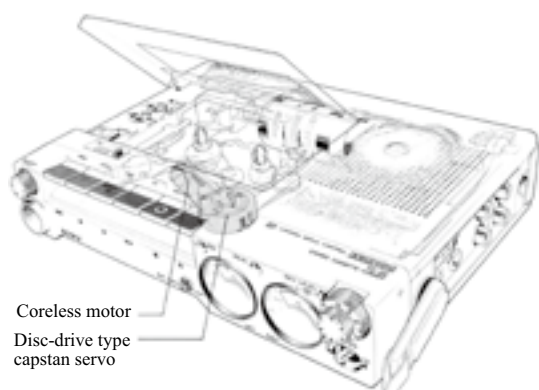

Fig. 6.19. Perspective drawing of the TC-D5 drive system ⁽¹⁶⁾

6.12 Other Cartridge Tape Recorders

While the early Compact Cassettes lacked the capability for music recording, Japanese audio equipment manufacturers worked hard on improving performance within the tightly

constrained standards, revising and improving the tape heads and the drive system, including the mechanisms and the motor. The resulting superior cassette decks hit the markets as fully recognised items of audio equipment. The Japanese audio equipment industry steadily gained confidence through competitive development and eventually decided to set new, Japan-specific industry standards.

(1) Micro-Cassette

The Micro-Cassette is a tape recorder that uses small-scale cartridges around one quarter the size of the Compact Cassette. The tape width was 3.81mm, the same as the Compact Cassette, while the available tape speeds were 2.4cm/s and 1.2cm/s. With standards set by Olympus, it was put on the market in 1969 as the Pearlrecorder. In 1974, Olympus, Sony and Matsushita set their own standards together and each company released a small-scale memo recorder. While it gained some popularity due to its small size, it never reached as extensive a range of uses as the Compact Cassette.

(2) Elcaset

The Elcaset was a tape recorder standard jointly developed and announced in 1976 by Sony, Matsushita and TEAC that combined the sound quality of the open reel with the ease of use of the Compact Cassette. The tape width was 6.3mm, the same as the open-reel machines, and the tape speed was 9.5cm/s. The tape came out in A6-sized cartridges. Although products were developed and marketed by the three companies, they were not widely popular and soon disappeared from the market.

While both of the above new Japanese standards sought to perfect aspects lacking in the Compact Cassette, they were not widely popular. They were neither very marketable nor very necessary, since they served only to supplement what the Compact Cassette lacked. Compact Cassette machines had had a head start in development; they were also being produced in large quantities and therefore at lower cost. However, Japan's achievements in developing international standards proved to be an invaluable experience when Japan later led the world into the digital era.

References

- 1) 50 Years of Audio. Japan Audio Society Publishing, December 1986, p. 483.
- 2) Mori, Yoshihisa, et. al. Onkyō-Gijutsu-Shi [History of Sound Recording], Tokyo University of the Arts Press, March 2011, p. 57.
- 3) 50 Years of Audio, p. 498.
- 4) Ibid., p. 499.

- 5) Onkyō-Gijutsu-Shi, p. 88.
- 6) Ibid., p. 89.
- 7) 50 Years of Audio, p. 500.
- 8) Ibid., p. 503.

- 9) Provided by Panasonic Corporation.
- 10), 11), 12), 13), 14), 15), 16) Provided by Sony Corporation.

7 | Structure and Performance of Compact Cassette-Type Tape Recorders

7.1 Types of Cassette Tape Recorders According to Head Arrangement

Although Compact Cassette machines started out as so-called memo recorders and were initially limited in terms of function and performance, as the competition for standardisation ended and the Compact Cassette became recognised as the standard format, development rapidly began on increasing its functionality and performance. The original construction was in cartridge form and presumed a two-head configuration only: an erase head and a recording/playback head. Various head formations were devised, but in the end the head formation that had been put to use in

the freer open-reel era was carried over into the Compact Cassette as well. Fig. 7.1 shows the various Compact Cassette tape recorder formats.

7.2 Basic Structure

Fig. 7.2 shows the basic structure of a tape recorder. The input signal passes through the equaliser after being adequately amplified; it is then applied to the recording head with the bias signal added to it. The tape moves in front of the head (Fig. 7.3) at a fixed speed and is magnetised in proportion to the strength of the magnetic field coming from the gap in the recording head, thus recording is achieved.

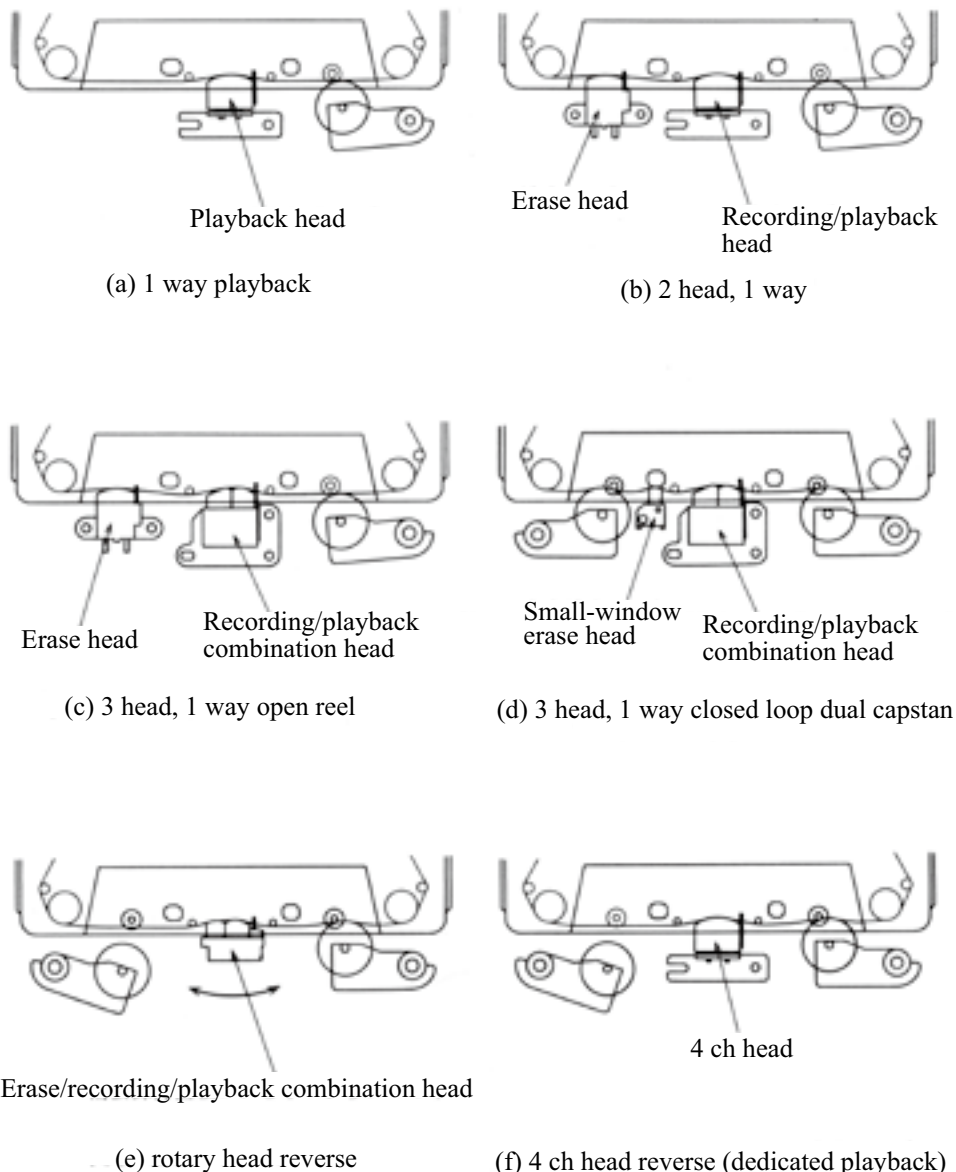

Fig. 7.1. Compact Cassette tape recorder formats and head arrangement⁽¹⁾

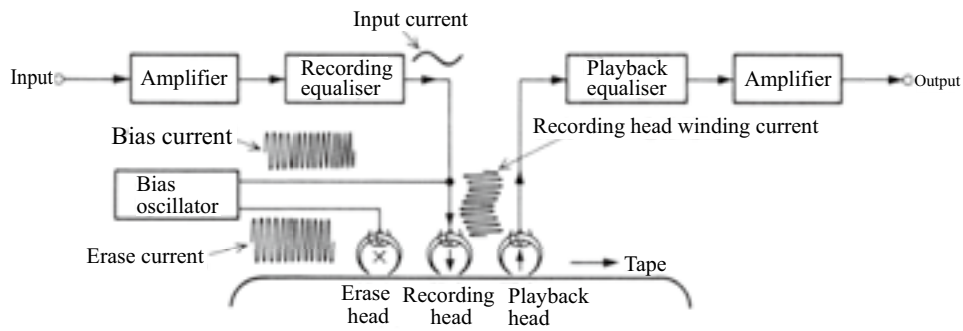

Fig. 7.2. Basic structure diagram of a tape recorder ⁽²⁾

When the recorded portion of the tape is rewound and passed by the playback head at the same speed, the magnetic flux on the tape passes through the gap to the head, inducing a current corresponding to the magnetisation on the tape when the tape was wound. Playback is achieved by this signal being output through the playback amplifier.

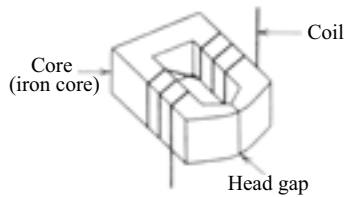

Fig. 7.3. Diagram of the magnetic head principle ⁽³⁾

7.3 Recording mechanism

The magnetisation curve of tape is represented by what is called a hysteresis curve rather than a straight line. As a current passes through the head coil, the magnetisation of the tape that is in contact with the gap alters in a hysteresis loop pattern in response to variations in the magnetic field H . As the tape moves, the magnetic field applied to that particular point on the tape returns to 0 once it has gone past the gap. If the applied AC current (recording signal) has a high frequency, the magnetic field is reversed and returns to 0. Consequently, while residual magnetisation is achieved in a small loop, the recorded magnetisation waveform is greatly distorted because the initial magnetisation curve is non-linear. Accordingly, a sine wave is passed through the recording head at a higher frequency than the recording current as a means to avoid this distortion. This is called AC bias recording and is an indispensable piece of technology for ensuring good electromagnetic conversion in analogue recording (see Fig. 3.6).

7.4 Loss during Recording

Loss (signal attenuation) at the recording head tends to be greater the higher the frequency, as shown in Fig. 7.4. Self-demagnetisation loss is the mutual negation of adjacent magnetic flux as the recorded wavelength on the tape decreases. Recording demagnetisation loss increases the higher the frequency; like AC bias, at very high frequencies the minor loop converges at 0 and nothing is recorded. Penetration loss is loss caused by differences in magnetisation between the surface of the tape and the deeper levels of magnetic particles on the tape due to different depths of magnetisation on the tape. Core loss is loss caused by eddy currents in the head core. Recording spacing loss is loss caused by a space forming between the tape and the head gap; however, this has less effect during recording than during playback.

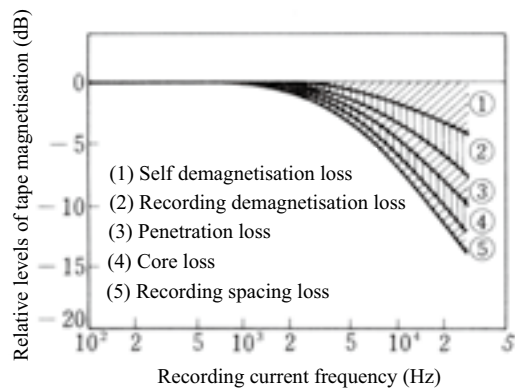

Fig. 7.4. Loss during Recording ⁽⁴⁾

7.5 Loss during Playback

Ideally, a playback head should increase in output in proportion to frequency. In reality, however, various losses occur when a tape is played back (Fig. 7.5). Gap loss is loss

caused by gap width: if the recorded wavelength is equal to the gap width, there is no output. Playback spacing loss is loss due to a space forming between the tape and the gap in the playback head. This can be caused by the surface properties of the tape, the tape driving performance, the tape tension or other factors. Azimuth loss is caused by a misalignment between the playback head gap and the azimuth angle of the recorded signal (determined by the relative position of the recording head gap and the tape). Spacing loss and azimuth loss are largely due to tolerances of the core mechanisms of the tape recorder, including the tape drive system. Particular attention needs to be paid to this when designing mechanisms. Since there are limited options for head arrangement on Compact Cassette machines in particular, it is very difficult to improve azimuth precision on reverse machines and three-head machines. Head arrangements with no pads inside the cassette (such as heads that are inserted through a small window) cannot ensure proper contact between the tape and the head and are thus susceptible to spacing loss. Thickness loss is loss related to the effective depth of magnetisation during playback.

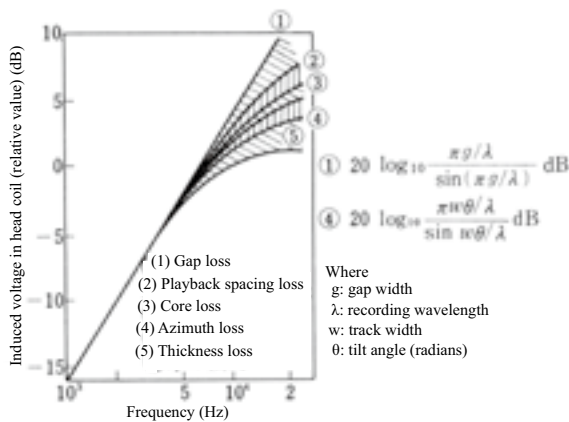

Fig. 7.5. Losses during playback⁽⁵⁾

7.6 Playback Equaliser

A characteristic of magnetic recording is that although the output of the playback head is relative to the speed of variation in magnetic flux, certain losses are evident at high frequencies. Consequently, a balanced frequency response can be achieved in a tape recorder through playback compensation (equalising) that separates the mid and low frequencies, where loss is negligible, from the high frequencies, where loss is not negligible. This had to be standardised relatively early on, because there would be little compatibility between machines if every different device were to make this compensation in a different way. Compact Cassette machines had different playback equalisers for each

tape type. Equalising low frequencies meant increased noise with any rise in gain, so the low frequency time constant was flattened (Fig. 7.6).

IEC Type Number	Time Constant (μ s)		Folding Frequency (Hz)	
	T_1	T_2	f_1	f_2
I (normal tape)		120		1326
II (chrome tape)	3180	70	50	2274
III (ferrichrome tape)				
IV (metal tape)				

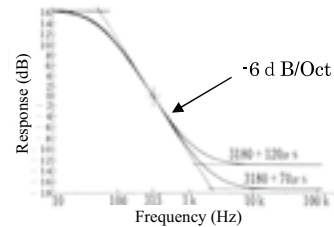

Fig. 7.6. Compact Cassette playback equaliser⁽⁶⁾

References

- 1) Saishin Ōdio Gijutsu [Latest Audio Technology], Ohmsha, April 1991, p. 158.
- 2) Ibid., p. 146.
- 3) Ibid., p. 146.
- 4) Ibid., p. 150.
- 5) Ibid., p. 151.
- 6) Ibid., p. 153.

8 | Magnetic Tape in Compact Cassettes

8.1 Development of Magnetic Substances

Development of ferric oxide magnetic tape continued with the basic aim of trying to improve its recording performance. Unlike the open-reel system, the Compact Cassette tape recorder system meant very little freedom in terms of tape width, tape speed and head formation. Since compatibility had to be strictly adhered to, there was a strong demand to improve the performance of the magnetic tape itself. The early Compact Cassette tapes were lacking in performance in terms of music recording. Development of magnetic substances quickly got under way in order to make this system into an all-purpose tape recorder for recording everything from conversations to music.

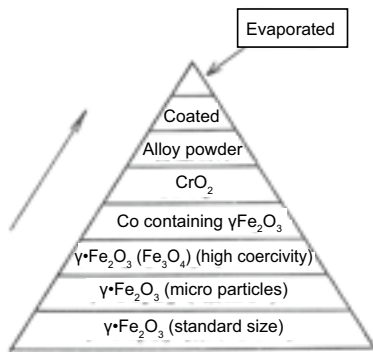

Fig. 8.1. Estimated development of magnetic substances on tape⁽¹⁾

Fig. 8.1 is a chart proposed in the 1970s showing the estimated development of magnetic substances on tape. First, attempts were made to physically improve the tape and magnetic substance by developing and improving the magnetic ferric oxide powder, increasing the packing ratio by making the particles smaller and improving the tape's adherence to the head by making the tape surface smoother. At the same time, improvements were being made to the process of applying the magnetic powder to the tape, as well as to the adhesives and additives, the so-called binders, that went into the magnetic powder. Work was also being done to improve the mechanical precision of the tape by improving the tape cutting machines (slitters) and other elements in the manufacturing process, enabling the creation of a more delicate and higher-precision tape than open-reel tape. However, the most important tasks were to downsize the product and improve its ease of use. Developers had very constrained conditions under which to achieve proper

recording performance, so they had to focus on developing and improving the magnetic substance itself to improve tape performance. The Compact Cassette philosophy of strictly maintaining compatibility not only spurred on product development, providing users with small, lightweight tape recorders that were easy to use, but also forced developers to improve the performance of the technology under very restrictive conditions. This was the driving force that made the development of the Compact Cassette so definitive.

8.2 Development of Chrome Tape

In 1970, BASF released a "chrome tape" that used chromium dioxide as the magnetic substance. This tape was a major improvement in terms of a high-frequency response that could not be achieved with ferric oxide tape. Up until this time, all Compact Cassette players had a playback equaliser time constant of $120\mu\text{s}$; the arrival of the chrome tape meant a time constant of $70\mu\text{s}$ could be used. This became the standard value for high frequency compensation for high-performance tape. Once BASF developed its chrome tape, Japanese manufacturers also came up with their own chromium dioxide tape. In 1973, Sony released its "DUAD tape", double-coated with ferric oxide and chrome. The ferric oxide layer on this tape compensated for the lack of energy (or lack of sensitivity) in the mid and low frequency range that was a shortcoming in chrome tape. In turn, the high frequency response of chrome made this a high performance tape. Although this type of tape became standardised as the Type-III, it was not highly popular and went out of use in the 1980s. Although double-coated tape had a reputation for good sound quality and had also been used in open-reel systems, it faced pressure from the high performance and price competitiveness of Type-II tapes such as cobalt tape. When metal tapes appeared, it lost much of its purpose and exclusive Type-III products faded from the market. While chrome tape was ground-breaking in terms of high frequency response and played a huge part in improving the performance of Compact Cassettes, it gradually disappeared off the market in Japan due to patent licencing issues and pollution issues with hexavalent chromium effluent from coating factories. Instead, cobalt-deposited ferric oxide (CoFe_2O_4 , crystal growth of cobalt ferrite on the surface of ferric oxide) tape with similar properties became the main high-performance music tape in use. Eventually, most of the Type-II tape was this so-called "cobalt tape".

8.3 Appearance of Metal Tape

With stereo records becoming popular and FM broadcasts reaching full swing in the late 1960s, the audio market flourished. The Japanese audio industry entered a phase of furious development in exports. While Compact Cassette machines were a mainstay of this trend, as the audio market expanded, there was increasing demand for further performance improvements in the Compact Cassette. The magnetic properties of the tape had to be improved, but the standards had to be strictly maintained. The race was on to get a new, high-performance magnetic substance out of the laboratory and onto shop shelves. Developers first came up with chromium oxide; the next development was cobalt. Finally, they came up with metal tape (metal powder tape) and set about putting it to practical use. Nagai, Iwasaki, et al. had already reported some research results at Tohoku University regarding tape for short wave recording around 1963. Although this was recognised to have better qualities in theory, there was no obvious need for the product and no incentive to solve the various difficulties faced in manufacturing it. High-performance Compact Cassettes presented such a need, and metal tape, originally considered to be for video use, was put to practical use.

Despite being called metal tape, it was actually a type of coated tape very similar in composition to the existing ferric oxide tape rather than a completely new composition, such as the evaporated tape discussed in a later section. The difference was that the magnetic substance used was metal particles (iron). This meant a superior magnetic substance compared to ferric oxide because the lack of oxygen atoms increased the density of the metal, thereby adding to the magnetism of the substance; however, it was also very susceptible to oxidation. It was important to develop anti-oxidation or rust-proofing measures to be incorporated into the tape manufacturing process, as well as a method for producing metal particles. A number of companies tried to solve this issue through various means, such as coming up with different binder materials or putting anti-rust properties into the magnetic particles themselves. A major argument was the lack of compatibility: the tape was highly retentive, and could not be recorded onto or erased using existing machines. However, such concerns were far outweighed by the desire for better sound quality, and a new standard, the Type-IV, was established. The final stage in the evolution of the Compact Cassette had taken place. The development of metal tape not only proved useful for audio, but also made a major contribution to the improvement, downsizing and digitalisation of small-scale video tape recorders and the development of audio and video equipment.

8.4 Creation of Practical Evaporated Tape

During the same period of time, Matsushita achieved another dream: thin metal film tape. Although thin metal film tape was considered ideal, as it does not require a binder like coated tape does, it required a new manufacturing technique to achieve such a product in tape form. Matsushita developed the evaporation coating method, in which an evaporated coating could be continuously formed on a base product (Fig. 8.2). It was originally developed as a means of evaporation coating for the production of film capacitor electrodes.

While evaporated tape offered superior magnetic properties, it also had several flaws when used in tape recorders. It adhered to the head very well, as the surface of the tape was far smoother than coated tape; however, it could cause too much friction against the head and the tape guide, so an appropriate lubricant was required. The magnetic layer was very thin, so care had to be taken to ensure it did not deteriorate, even when highly durable materials such as nickel or cobalt were used for the magnetic film. These various hurdles were cleared and the first evaporated tape – “Ångrom” tape – was created for the microcassette in 1978. In 1984, an Ångrom Compact Cassette went on sale as a Type-II tape. This evaporated tape was later developed for use in video, just as the metal tape was, and full use was made of its high density recording properties. It became a very important tape in the era of audio/video digitisation.

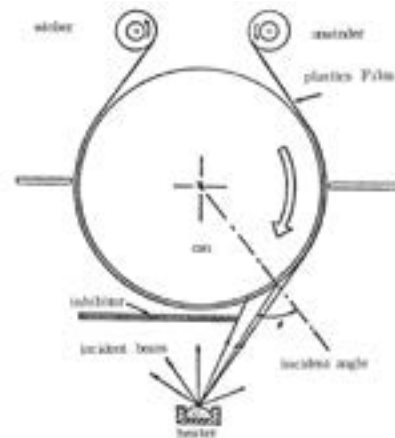

Fig. 8.2. Example evaporation-coating device⁽²⁾

References

- 1) Jiki Kiroku Gijutsu Dai 3-Kan [Magnetic Recording Technology Volume 3], Japan Industry Engineering Center, May 1980, p. 87.
- 2) Jiki Kiroku Gijutsu Dai 3-Kan [Magnetic Recording Technology Volume 3], Japan Industry Engineering Center, May 1980, p. 89.

9 | Advances in Magnetic Heads for Compact Cassettes

9.1 Recording/Playback Head Structure

Magnetic heads used in tape recorders comprise a magnetic circuit of a coil wrapped around an iron core with a part cut away. Magnetic recording occurs when a magnetic field is applied to the tape through this cut-away section, or gap. For playback, the magnetic flux on the tape passes through the gap, inducing a current in the coil, which is then amplified (see Fig. 9.1). The core material must be sensitive to microscopic changes in magnetism. Since high magnetic permeability is needed to increase the effectiveness of the magnetic circuit during recording, many of the early heads were made of permalloy, an alloy of nickel and iron with high magnetic permeability. The magnetic head is a wound coil with impedance that increases in proportion to frequency. As a result, the higher the frequency, the greater the “core loss”, loss caused by eddy currents. To reduce this core loss, a laminate structure is used, made up of several layered sheets of permalloy (Fig. 9.2). The head is also designed so that the magnetic circuit is narrower near the gap, so as to increase the effectiveness of the exchange of magnetic flux. The front part of the head that comes into contact with the tape is called the tape contact surface. Since it is in constant contact with the tape, it is very important for it to be abrasion-resistant; it must have very smooth frictional properties so as not to adversely affect the running of the tape. In actual heads, the contact surface comprises a shield between tracks (if there are multiple track heads, such as for stereo), a dummy segment without tracks and a resin material to hold these in place. If these different materials do not wear evenly, this affects the contact with the tape and may result in spacing loss. Accordingly, every head-manufacturing company has come up with its own ideas on which materials to select and how to polish the contact surface.

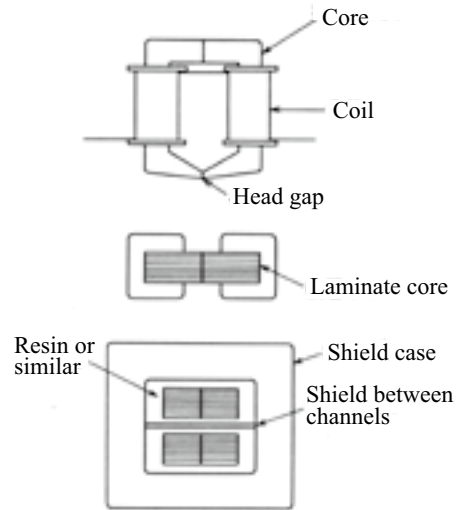

Fig. 9.1. Typical magnetic head structure ⁽¹⁾

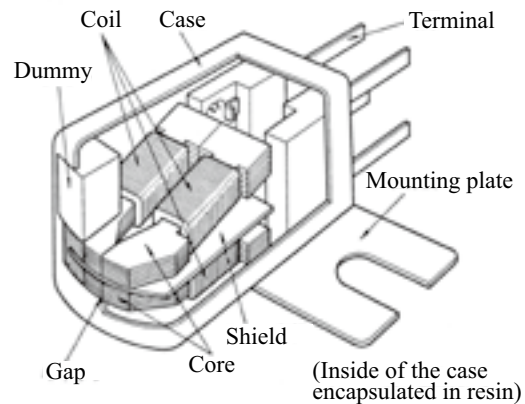

Fig. 9.2. Laminated head structure ⁽²⁾

9.2 Types of Heads and their Characteristics

(1) Recording Heads

The aim of these heads is to generate a large and effective magnetic field with very little current and magnetise the tape precisely and accurately. They are configured to have a slightly larger gap of around 3-5 μm to avoid magnetic saturation at the gap and increase the effectiveness of the recording penetrated into the tape. Impedance is set to 10 Ω at 1kHz for an electrical circuit providing a bias current

(2) Playback Heads

The priority for these heads is to reduce gap loss in order to play back at as high a frequency as possible. Accordingly, they have a far narrower gap than recording heads, at around 1.0 μm . Since they have an increased number of winds in

the coil to make the playback output as high as possible (increased sensitivity), they automatically have a high impedance of $1k\Omega$ at $1kHz$. As well as being highly sensitive, playback heads are connected to a playback amplifier, so require strong magnetic shielding to prevent external magnetic induction and noise generation.

(3) Recording/Playback Combination Heads

The basic two-head type Compact Cassette tape recorders use the same head for recording and playback in order to make the device simpler and keep the price down. Many of these recording/playback heads have a gap of $1.3\text{-}1.6\mu\text{m}$ in consideration of magnetic saturation during recording as well as gap loss during playback. Since the parameters of these heads are not optimum for either recording or playback, they are inferior in performance to the three-head type, which uses individual recording and playback heads. However, for as long as Compact Cassettes used ferric oxide, they achieved adequate high-end performance.

(4) Erase Heads

Many AC erase heads use ferrite materials, which generate strong magnetic fields with little heat generated from eddy currents. But with the appearance of metal tape, erase heads needed to generate even stronger magnetic fields. Although Sendust erase heads were developed that could achieve this, they were extremely cost-prohibitive, so other alternatives were devised, such as improving the ferrite material and increasing the number of gaps (Fig. 9.3). Low-cost, popular-model machines were not really capable of playing and recording on high-performance tape such as metal tape. Many of them used a DC erase method with erase heads made from permanent magnets. In such cases, rather than simply using a magnet, the head surface was magnetised in an N-S-N-S arrangement to give the effect of AC erasure as the tape passed by. Combination products such as radio cassette players often used permanent magnet erase heads to avoid causing radio interference with a strong magnetic field (Fig. 9.4).

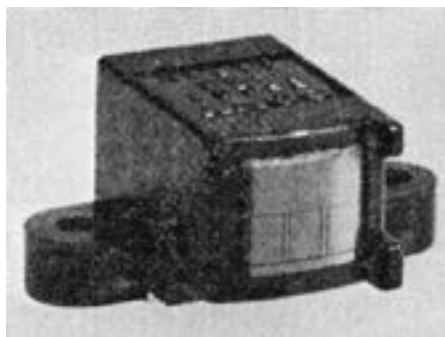

Fig. 9.3. Four-gap ferrite erase head⁽³⁾

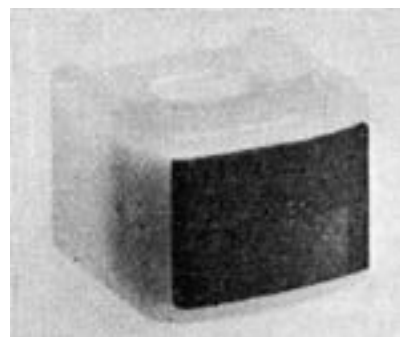

Fig. 9.4. Permanent magnet erase head⁽⁴⁾

9.3 Advances in Materials for Magnetic Heads

9.3.1 Ferrite Heads

The Compact Cassette started out using ferric oxide tape. As these tapes became more widely used, it became a major challenge to solve the quality performance issue resulting from narrow track width and slow tape speed. In the late 1960s, stereo records, which were already firmly established as a music medium, improved greatly in sound quality due to improvements in recording and cutting technology, creating an even greater demand to improve the sound quality of consumer tape recorders. While development continued on high-performance open-reel machines such as studio recorders, this was increasingly heavy-duty equipment for analogue recording and therefore highly priced. Naturally, this resulted in a greater demand in the home audio and car audio markets for a small-scale, affordable machine that could record and play music on Compact Cassettes. As discussed in Section 8.2, researchers worked on improving the magnetic substance on tape, creating chrome tape in 1970. This tape was superior in a wide range of applications and succeeded in expanding the existing recording and playback bandwidth of $10kHz$ to around $15kHz$, which could comfortably be called Hi-Fi. In terms of compatibility, a new “Chrome Position” (later Type-II) was defined, with a high-frequency playback time constant changed from $120\mu\text{s}$ to $70\mu\text{s}$ to match the rise in high-frequency sensitivity. While

the greater recording and playback performance of chrome tape played a major part in Compact Cassette machines being accepted as audio equipment, the surface of the tape was harder than ferrite oxide tape and caused problems with wear on the heads. To solve this problem, developers brought out an abrasion-resistant ferrite head (Fig. 9.5). Since ferrite is made of compression-moulded powder, it has relatively low manufacturing costs. It forms a hard core material following sintering, but this is easy to grind or cut and therefore easy to achieve dimensional accuracy. As well as being very hard and resistant to wear, ferrite heads also offer a very dimensionally stable gap, with glass layers fused between layers of ground core material. They maintain their initial properties for a very long time and are extremely stable even with changes in temperature and humidity (Fig. 9.6).

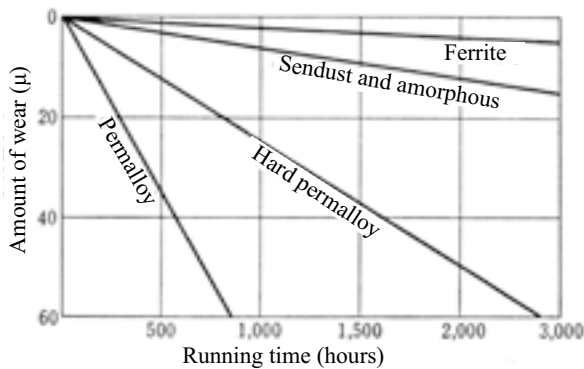

Fig. 9.5. Wear properties according to head material ⁽⁵⁾

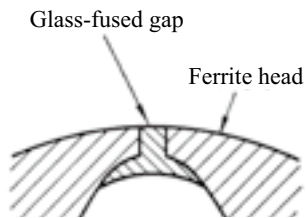

Fig. 9.6. Ferrite head gap structure ⁽⁶⁾

Sony had used ferrite heads in open-reel machines from a very early stage. It used ferrite not only for the core material, but also the entire contact surface of the head, including the dummy segment. This rugged and highly abrasion-resistant head was called the “F&F Head” (Fig. 9.7) and also became widely used for Compact Cassettes.

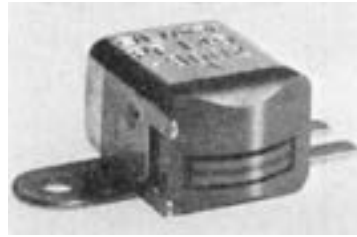

Fig. 9.7. F&F Head ⁽⁷⁾

9.3.2 Sendust Heads for Metal Tape

Metal tape appeared in 1978 at the onset of the digital audio era. This tape was the music tape trump card for the Compact Cassette, able to record and play back sounds that required a high resolution and a large dynamic range, like computer music. While it was understood that metal tape had groundbreakingly superior magnetic properties because it used a magnetic substance of metal powder rather than oxide, this contravened the Compact Cassette policy of “maintaining compatibility”.

In short, metal tape used a strongly magnetic substance. Compared in terms of coercive force (saturation flux density) H_c and maximum residual magnetisation B_r , the values for the existing chrome (cobalt) music tape were in the vicinity of $H_c=600-700\text{Oe}$, $B_r=1500\text{G}$, while the values for metal tape were almost double at $H_c=1000\text{Oe}$, $B_r=3000\text{G}$. H_c represents the high frequency recording level (the quality of the high-frequency response) as well as the ease of erasing or the strength of the magnetic field required for magnetisation. The ferric oxide tape first used in Compact Cassettes had an H_c of 350-400Oe. While this value was higher for chrome tape, the existing heads were still adequate for erasing and recording. However, to record at full capacity on $H_c=1000\text{Oe}$ metal tape required a stronger magnetic force and a greater bias current in the head. Since the existing head materials (permalloy or ferrite) had a low saturation flux density, any increase in current flowing through them would simply convert to heat rather than provide any effective increase in magnetic flux. Likewise, there was a fatal compatibility flaw for erasing, as the existing erase heads would not erase the tape. A discussion commenced on whether or not to change the high frequency time constant for chrome tape from $70\mu\text{s}$ to 50 or $35\mu\text{s}$ to make a marked improvement in high-frequency response during playback. One opinion said that the latest technology should be actively incorporated, because fussing over standards and compatibility prevented technological progress, but this meant that the compatibility that was such an important factor in the Compact Cassette would be likely to come undone. However, the latest improvements in performance were sought after in the music scene and could not be ignored. The EIAJ (now JEITA) formulated an international standard in a short space of time with the help of international organisations such as IEC and

metal tape Compact Cassettes were introduced. The playback time constant was set at 70 μ s, the same as for chrome tape. Although the compatibility policy had been closely adhered to for playback, such as maintaining playback on existing machines, a new head (with more efficient materials and design to suppress heat and prevent saturation even with a high bias current) was absolutely necessary for recording. While ferrite was used in large quantities in high-performance heads due to its superior abrasion-resistance and the ease and low cost of manufacture and production, it was unsuitable for metal tape due to its low saturation flux density of around 5000G. Sendust gained much attention at this stage (Table 9.1). Sendust is an iron-aluminium-silicon alloy invented in 1935 by Dr. Hakaru Masumoto and others at the Tohoku University Institute for Materials Research and used as a magnetic powder core before ferrite was discovered. Although it has superior magnetic properties and has cost benefits due to the abundance of raw materials for it, it has limited uses as it is extremely hard and brittle as a metal (alloy) and difficult to roll out like permalloy. Nevertheless, it gained immediate attention with the advent of metal tape. The worst characteristic of Sendust was its difficulty in processing. While vacuum-melted Sendust ingots were cheap, it was expensive to grind and polish them to make heads. Usually, heads had a laminated structure, made up of ground and polished cores 0.2-0.3mm thick. This thickness was a compromise to keep processing costs down; even thinner layers would have been better for high-frequency response. Various attempts were trialled to make a thinner product, such as the method of melting at high temperatures and then rapidly cooling the alloy in ribbons (ribbon Sendust) or an attempt at rolling the alloy, but it was not suitable for mass head production due to the difficulty in handling the brittle ribbon. One possible method to curb high-frequency loss was the composite S&F Head (Figs. 9.8, 9.9), with the tip of the head made out of a small block of

Sendust, thus making the gap area highly magnetic, while the rest, which did not need to be so strongly magnetic, was made out of ferrite, which has hardly any high-frequency loss. The gap area had more or less the same structure as that of a ferrite head (Fig. 9.10), with the abrasion-resistance of Sendust rivalling that of ferrite. The product was welcomed as a highly reliable, long-life device. Sony, Matsushita and other companies made this type of head; these were widely used in high-performance cassette tape recorders from the metal-tape era onwards.

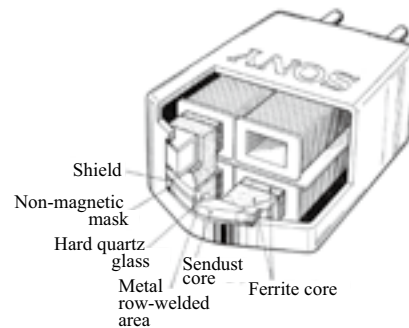

Fig. 9.8. S&F Head structure ⁽⁹⁾

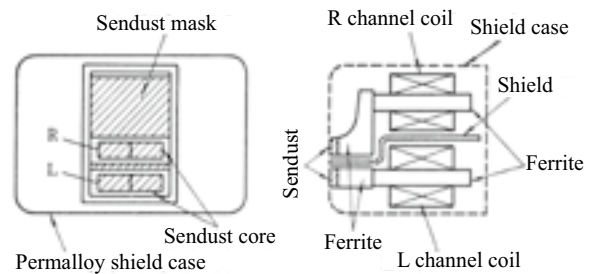

Fig. 9.9 S&F Head magnetic circuit ⁽¹⁰⁾

Table 9.1. Characteristics of Magnetic Head Core Materials ⁽⁸⁾

Material		Initial permeability μ_i			Magnetic flux density Bs (gauss)	Coercive force Hc (Oe)	Specific resistance ($\mu\Omega\text{-cm}$)	Hardness (HV)	Density (g/cm^3)	Magnetostriction constant λ_s ($\times 10^{-6}$)	Core thickness (μm)
		1kHz	10kHz	100kHz							
Ferrite	Rec/Play	10,500	9,700	8,800	4,500	0.03	10^6	680	5.0	5.0	
	Erase	3,500	3,300	3,300	5,000	0.14	10^9	700	4.9	2.0	
Permalloy	Popular	39,000	11,700	2,000	7,800	0.012	55	110		1.5	50
	Hard	45,000	10,000	2,100	6,600	0.013	65	200	8.7		100
	HiB	15,000	4,300	930	8,100	0.03	55	150			100
Sendust	Popular	15,000	3,800	810	8,500	0.007	85	500		1.0	150
	HiB	11,800	3,200	720	10,000	0.025	85	480	6.8	1.0	150
Amorphous	HiB	20,000	9,000	3,000	11,500	0.02	140	850	8.1	0	30
	Hi μ	50,000	40,000	9,000	8,000	0.012	140	850	7.7	0	30



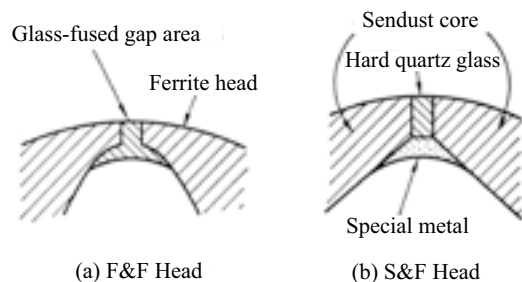

Fig. 9.10. Comparative gap areas structures ⁽¹¹⁾



Fig. 9.11. S&F recording/playback head ⁽¹²⁾
Head for metal tape compatible cassette deck

9.3.3 Adoption of Amorphous Alloy Head Material

Although a lot of Sendust was used in heads for metal tape, its saturation flux density was slightly reduced, as other elements such as chrome and molybdenum were being added to it to increase its durability as an audio head. While successive studies were made on how to improve it by modifying the type or amount of additives, it was impossible to achieve a saturation flux density any higher than 10,000G.

Amorphous alloys emerged as a more effective head material that could transcend this limitation. Non-crystalline amorphous alloys differed in various ways from existing metals with a crystalline lattice structure. When metals melt at high temperature, they have a completely random arrangement of atoms; if they are rapidly cooled, they retain this property even at normal temperatures, thus forming an amorphous alloy. The cooling rate to achieve this is around 10,000-1,000,000°C/s. In practice, amorphous alloys are made by pouring molten metal from a fine nozzle over a cooling roller rotating at high speed, thus creating a ribbon (Fig. 9.12). At around 30-50µm, this ribbon is of a suitable thickness for use as a head material; it is easy to make into a laminate core by layering it (Fig. 9.13).

Soft magnetic amorphous alloys are made from a combination of ferromagnetic metals such as iron, cobalt and nickel, and metalloids necessary for amorphisation, such as phosphorus, carbon, boron and silicon. Harder than ferrite at Hv=800+ and with the same or slightly higher abrasion-resistance than Sendust, they are perfectly suitable material for audio heads. The higher performance amorphous

heads took over from Sendust heads, first used in high-end machines such as three-head decks, then in other devices competing for high sound quality (Fig. 9.14).

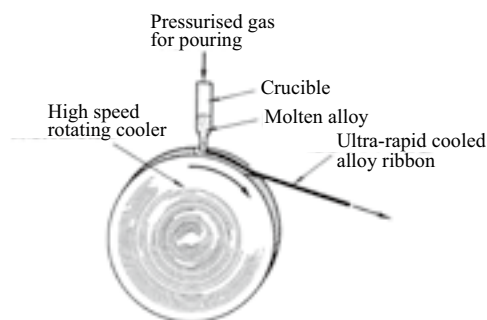

Fig. 9.12. Diagram of the rapid cooling principle ⁽¹³⁾

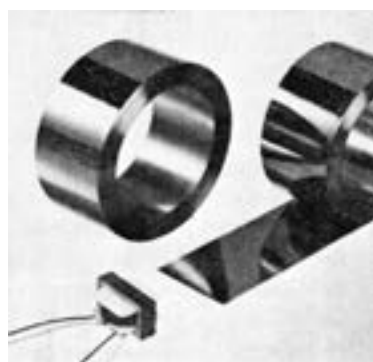

Fig. 9.13. Amorphous alloy ribbon ⁽¹⁴⁾

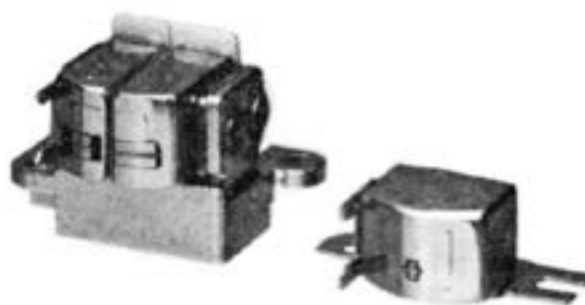

Fig. 9.14. Amorphous head ⁽¹⁵⁾

References

- 1) Saishin Ōdio Gijutsu [Latest Audio Technology], Ohmsha, April 1991, p. 156.
- 2) – 15) Takahashi, Shiro. “Jiki Heddo Zairyō no Saikin no Dōkō [Recent Trends in Magnetic Head Materials]”, JAS Journal, 1981, Vol. 21, No. 10.

10 | Development of Three-Head Compact Cassettes

10.1 Advantages of the Three-Head Format

The two-head type is generally thought of as the standard Compact Cassette. The idea is that the cassette is vertically symmetrical and both sides can be used by turning the cassette over. This basic concept is very important, as it rapidly boosted usability, providing tape recorders with a necessary and sufficient function. The basic specifications, such as tape speed, width and magnetic properties, were also thought to provide sufficient functions for the expected users and usage environment. Compact Cassette machines, which had started out as simple “memo tape recorders”, had successfully become the de facto standard. Once they came to be regarded as mainstream tape recorders, rapid technological developments took place to improve their sound quality and performance. When improving the performance of open-reel tape recorders, developers had been quite free to select any tape speed as well as the shape and number of heads. Since it was straightforward to use heads optimally designed for recording, playback and erasing, it was inevitable that a three-head system was adopted. Of course, even for open-reel machines, two-head systems were more typical among popular-model machines and simple head arrangements, such as DC erasing, were used in small, battery-operated machines. However, one major advantage in all of these machines, from popular-model machines to high-performance machines and even business machines, was that there was free choice in terms of heads. In practice, most stereo tape decks used the three-head format.

While the main aim of the three-head format was to improve the sound quality when recording, a major advantage was that running the playback head during recording made it possible to have a “recording monitor”. When recording on ordinary two-head tape recorders, the sound from the microphone or line in was adjusted as necessary using a preamplifier then sent to the recording amplifier. The sound monitored during recording was the output from the preamplifier, or the “sound being recorded”. Of course, some machines had level meters for adjusting the volume and other functions that made it easier to produce a better recording, such as automatic levelling functions, but ultimately, the recording could only be checked by rewinding and playing back the tape after recording. While this presented no real problems in general use, in instances where the recording was vital, such as live recording, being able to monitor the recording, or the “recorded sound”, during recording provided a definite way to check the recording levels and

to check for any flaws in the basic components, such as the tape or heads, thus providing a very effective way to prevent mishaps. Monitoring during recording can only be achieved by having a three-head system with dedicated recording and playback heads. This is the “three-head” format. For open-reel systems, the head arrangement could be freely designed to suit the required performance and functions.

10.2 Three-Head Format for Compact Cassette

The Compact Cassette running system serves as a tape recorder by inserting heads and a pinch roller into the cassette. Fig. 10.1 shows the main components of a typical Compact Cassette tape recorder running system. There are three large apertures (generally called “windows”) on the face of the cassette for inserting the heads and the pinch roller. The central window has a felt-like component called a pad behind the tape, held in place by a leaf spring. When the head is inserted, this pad pushes the tape against the head to ensure contact is maintained between the tape and the head. Fig. 10.2 shows the face of a cassette. The left and right windows, for the erase head and the pinch roller, are symmetrical, so that when the cassette is turned over, they each insert into the opposite window on the so-called B side. These pinch roller windows are the large windows; there are also smaller apertures between these large windows and the central head window. These are the small windows; while they are designed to have various uses, such as using tape tension to detect the end of the tape and detecting the transparent leader tape (the start and end of the reel of tape, mostly with no magnetic substance on it), they are hardly ever used.

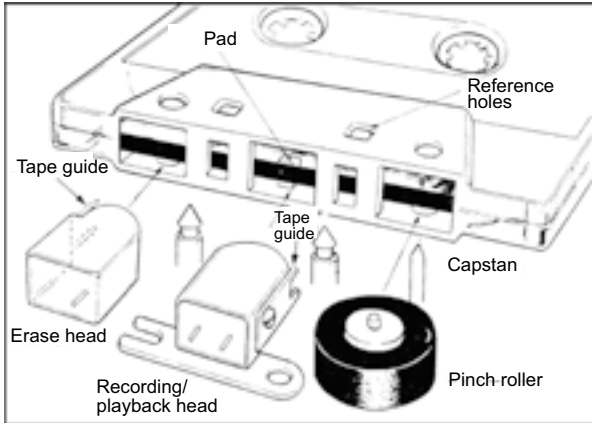

Fig. 10.1. Diagram of the relative positions of the cassette and structural components⁽¹⁾

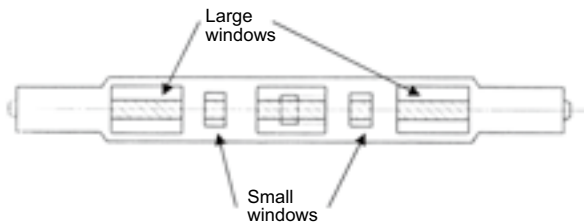

Fig. 10.2. Apertures on the face of a cassette

Given these constraints, it is difficult to implement a three-head format on a Compact Cassette and work out which head to put where. While various companies investigated various proposals (Fig. 10.3), the first format implemented used a system of standalone heads as shown in Fig. 10.3 (1).

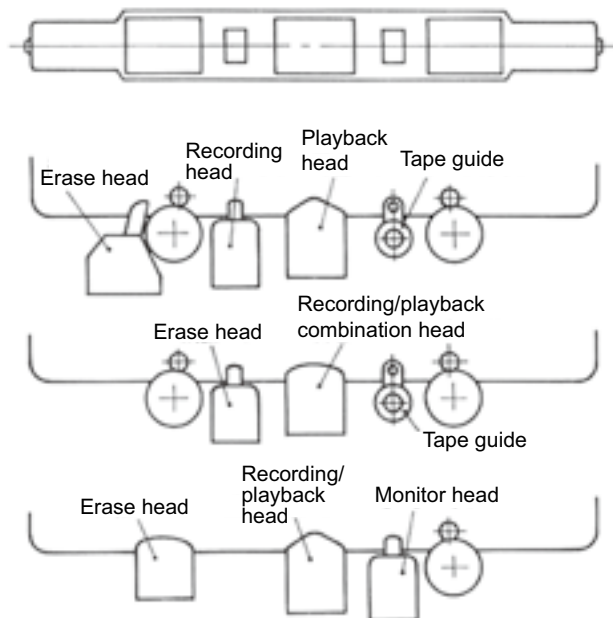

Fig. 10.3. Proposed three-head arrangements⁽²⁾

Although this format meant that heads very similar to the existing recording/playback heads could be used as playback heads, it was difficult to get any performance out of the recording head, as it had to be made smaller in order to fit into one of the small windows. Since the small windows had no tape pads, it was also difficult to maintain contact between the head and the tape. As a result, a high-end running system called a closed loop dual capstan had to be implemented to maintain tape tension within the loop (the area between the two capstans) to ensure recording performance. The erase head was placed on the outside of the upstream capstan; this head also had to have quite a special shape to prevent it from interfering with the pinch roller.

This three standalone head system was first incorporated into the Nakamichi 1000 (Fig. 10.4) by Nakamichi Corporation. This was an ultra-high-end tape deck with a price tag of over ¥200,000 when it first went on sale in 1973. Major tape recorder companies such as Sony and Matsushita were also working on similar developments around the same time; Sony released the TC-6150SD (Figs. 10.7, 10.8) in 1973, while Matsushita released the RS-690 (Figs. 10.5, 10.6) in 1975, both decks with three standalone heads. This proved that the Compact Cassette could have the same level of performance as open-reel machines. Users gained confidence that it could cover all areas from taking memos to high performance, again boosting the popularity of the Compact Cassette.

- (1) Three standalone heads format
 - Optimal head performance
 - Requires specially-shaped heads

- (2) Combination head format
 - Easy to access each head
 - Manufacturing of a combination head is key

- (3) Monitor head format
 - Recording/playback performance identical to the two-head format
 - Monitoring function during recording has been added



Fig. 10.4. Nakamichi 1000 (1973) ⁽³⁾
Upright style with the cassette inserted upside down



Fig. 10.5. Matsushita RS-690 (1975) ⁽⁴⁾
Mechanism and amplifier are separate



Erase head Recording head Playback head
Fig. 10.6. Heads used in the RS-690 ⁽⁵⁾



Fig. 10.7. Sony TC-6150SD (1973) ⁽⁶⁾
The standard horizontal cassette deck of the day

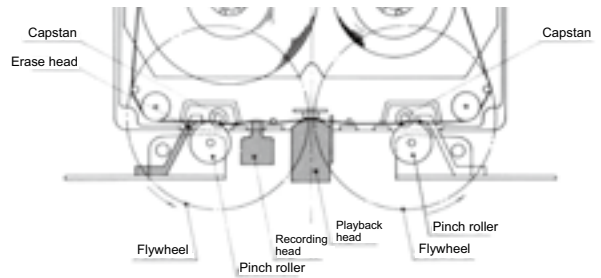

Fig. 10.8. Schematic diagram of the TC-6150SD running system and head arrangement ⁽⁷⁾

The three standalone heads format was optimised for performance. While it answered the call for the Compact Cassette to function as a music player, cost was a major limitation due to the special head shape; it was difficult to develop a low-cost model. As the recording head was inserted through the small window, it was sandwiched in the relatively narrow space between the guide pins on the cassette side, making it difficult to maintain precision in tape operation and contact between the head and the tape. As a result, the cassette was susceptible to azimuth loss during recording and playback and spacing loss during recording. The difficulty in maintaining mechanical precision and the adjustment processes required during manufacture only added to the cost. If a three-head system could be achieved using heads similar in size to the standard recording/playback head, then the same mechanism could be used, meaning a major reduction in cost. A “recording/playback combination head” was developed, integrating the recording and playback heads in one casing; this later became the main three-head system in use. While contact between the tape and the heads relied on a central pad, as it had previously, the pad was smaller than before, with a width of 4-5mm. It was therefore necessary to reduce the gap between the heads to around 2-3mm, which required advanced head processing technology. In the 1970s, the design and manufacturing technology for such electronic devices was quite advanced in Japan, meaning it was possible to produce a superior combination head (Fig. 10.9). The combination head had to accurately integrate the respective track heights (positions) for recording and playback, while at the same time eliminating any difference in head protrusion (front position) and also preventing azimuth loss by minimising the relative angle deviation between the two gaps. Accuracy had to be maintained on all these fronts during manufacturing and assembly. Another type of head – the “independent suspension type” – required such precise processing methods as well as azimuth adjustment following assembly (Fig. 10.10).



Fig. 10.9. Early combination head ⁽⁸⁾

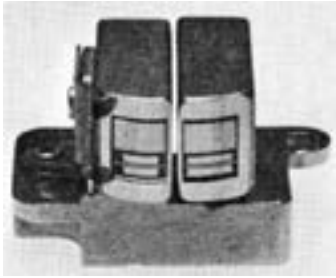

Fig. 10.10. Independent suspension combination head ⁽⁹⁾

Factors such as track position and head protrusion are integrated into the assembly, then the record head azimuth is adjusted after the set is completed

References

- 1) Tēpurekōdā no Kiso [Tape Recorder Basics]. Sony (Inc.) Technology Education Center, May 1985, p. 285.
- 2) Oki et al. National Technical Report Vol. 22, Panasonic (Inc.), August 1976, p. 425.
- 3) “JAS Jānarū Tokubetsu-gō: Tokushū Ōdio no Seiki [JAS Journal Special Issue: A Century of Audio]”, JAS Journal, 2001, Vol. 41, No. 10, p. 58.
- 4) Oki et al. National Technical Report Vol. 22, p. 423.
- 5) Hirota, Nakata. National Technical Report Vol. 22, Panasonic (Inc.), August 1976, p. 367.
- 6), 7) Provided by Sony Corporation.
- 8) Hirota, Nakata. National Technical Report Vol. 22, p. 367.
- 9) Takahashi, Shiro. “Jiki Heddo Zairyō no Saikin no Dōkō [Recent Trends in Magnetic Head Materials]”, JAS Journal, 1981, Vol. 21, No. 10.

11 | Noise Reduction Systems

11.1 Introduction of Noise Reduction Systems

Compared to the popular open-reel tape recorders, the early Compact Cassette machines performed too poorly at recording music to be placed among the ranks of serious audio equipment. Chapters 8 to 10 discuss the active development undertaken to improve the heads and the magnetic substance on the tape in order to boost the recording performance. However, one major factor in Compact Cassette machines gaining acceptance as proper audio equipment was the success of the noise reduction systems that began to be used in household tape recorders as a means of increasing the dynamic range by expanding the signal to noise ratio (S/N). When listening to sound recorded on tape, there was sometimes a bothersome hissing noise. This was often particularly noticeable when the music or audio was very quiet (low level); this is called a hiss noise and is quite audible because it largely comprises high-frequency components. The simplest way to reduce this noise is to cut out the high frequencies with a filter; however, this also cuts out the high-frequency component of the signal (music), resulting in a muffled sound with a narrower frequency response. One characteristic of the human ear is that background noise is very audible when listening to low-level sounds, although it is hardly noticeable when listening to loud sounds. It is possible to utilise this effect when recording quiet sounds by increasing the volume during recording and then decreasing the volume during playback, effectively playing back the sound in its original state and suppressing only the noise. In other words, this is a process of compressing/expanding the sound during the recording and playback processes. US company Dolby Laboratories, Inc. applied this principle and perfected a system that could be put to use in a business tape recorder. In 1966, British company Decca introduced the system for their in-house master tapes. This system, called the Dolby A, split the 20Hz-20kHz frequency range into four bandwidths, gaining a 10-15dB improvement in the S/N ratio through compression and expansion in each bandwidth.

11.2 Dolby B

The Dolby A system worked by compressing/expanding the entire sound bandwidth. While this method was easy to implement, it meant that the whole bandwidth would be manipulated even if only one frequency band had a high-level signal. This meant that the background noise would audibly fluctuate, resulting in a sound that was unnatural to

the ear. This side effect was a relatively minor problem if there were favourable noise conditions to begin with, but the strict Compact Cassette standards meant that they were very noise-prone. This made the sound distorted and muddy, which was difficult to correct by a masking effect alone. The Dolby A system was also complex in its circuitry, with the frequency range divided up and different operations for each bandwidth. Another issue was that this also cost a lot. The sensitivity of the human ear to different frequencies is well understood through the so-called “Fletcher-Munson curves”; there is actually a limited bandwidth that the ear hears well. Fig. 11.1 shows that humans are sensitive to sounds around 1-6kHz and less sensitive to higher or lower sounds. The Dolby B system achieved effective noise reduction by targeting and compressing/expanding sounds in this range of sensitivity as a countermeasure for the tape recorder hiss noise.

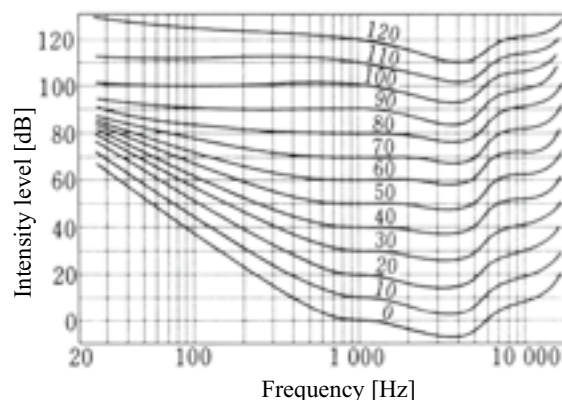

Fig. 11.1. Fletcher-Munson equal-loudness contour⁽¹⁾

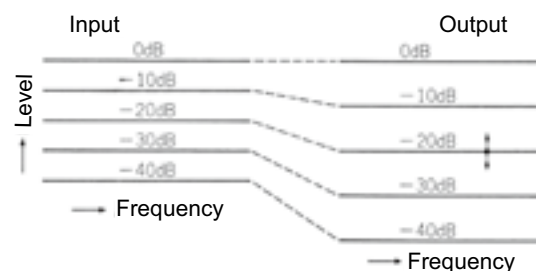

Fig. 11.2. Decoding using the whole-bandwidth level compression method⁽²⁾

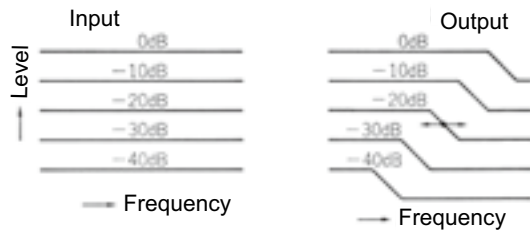

Fig. 11.3. Decoding using the sliding-band method ⁽³⁾

Fig. 11.2 shows the playback frequencies when the whole-bandwidth level compression method is used. The signal is expanded irrespective of frequency. In such cases, if there is a high-level signal at particular frequency, the entire bandwidth is subject to compression/expansion, resulting in less effective noise reduction. By contrast, Fig. 11.3 shows the playback frequencies when the “sliding-band” method adopted by the Dolby B system is used. The high-frequency range is expanded a fixed amount according to signal level. Even if there is a loud signal in the low- and mid-frequency range, a fixed amount of attenuation is ensured in the high-frequency range, which also suppresses other side effects, such as breathing*.

By keeping compression/expansion to a minimum, the Dolby B system prevented other side effects and was also relatively cost effective. As a consequence, it became widely used as a noise reduction system for the Compact Cassette. However, since it manipulated the signal in a relatively moderate manner, the resulting noise reduction effect was not all that large, usually around a 10dB improvement in the S/N ratio. As the digital audio era approached, further competition ensued to develop more effective noise reduction systems. Fig. 11.4 shows a comparison between the effect produced by the Dolby B and the more effective Dolby C, which was introduced later.

* When a signal-compressing/expanding noise reduction system such as the Dolby encounters a signal that varies greatly at a certain frequency, the noise reduction effect fluctuates as compression/expansion is carried out in response to this signal. This results in a fluctuation in background noise, which is unnatural to the ear. This phenomenon is called breathing.

11.3 Growing Popularity of Dolby Noise Reduction (NR)

The Dolby B noise reduction (NR) system was first released as a standalone unit, but it soon became incorporated into cassette decks. The first cassette deck with an inbuilt Dolby system was put out by TEAC in 1971 (Fig. 11.5). The Dolby B system suddenly grew in popularity as a standard cassette deck feature, with Sony releasing its first cassette deck with an inbuilt Dolby system, the TC-2250SD (Fig. 11.6), in 1972.



Fig. 11.5. Cassette deck with inbuilt Dolby B system TEACA-350 (1971)

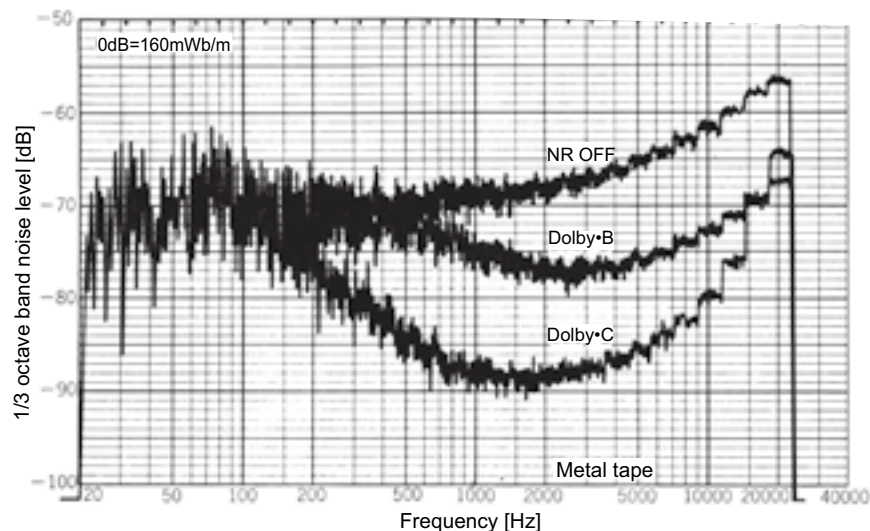

Fig. 11.4. Dolby noise reduction effects ⁽⁴⁾



Fig. 11.6. Sony TC-2250SD (1972)

Following the development of chrome tape, the Dolby NR system played a huge part in improving recording and playback performance. It later became monumental in tape recorder development history as having elevated the Compact Cassette from a memo recorder to a serious piece of audio equipment. While compressing/expanding noise reduction systems such as the Dolby are expected to have a greater effect and ensure a better sound quality than simply cutting noise with a filter, tapes with compressed recordings on them lose their compatibility, as they must be expanded and played in a predetermined manner. When the Dolby B came to the fore, it had no obvious rivals; it had the good fortune to take hold as the standard system in a relatively smooth manner. While Dolby Laboratories, Inc. started out in technology development, the company also became well-known for its successful licencing business model, having employed some clever technology agreement strategies when the Dolby NR system became popular. Although various other systems were later developed for noise reduction and some market competition ensued, the Dolby B continued to be used throughout as the standard NR system. The fact that its successor, the Dolby C, kept a number of rivals at bay and maintained its position as the standard system was probably due to a sense of security associated with the name “Dolby”.

11.4 Other Formats

While the Dolby B gained popularity as the de facto standard system, other competing systems were developed and put to use, as outlined below.

11.4.1 ANRS

JVC developed its own four-channel stereo record, the “CD-4”. It also developed its own noise reduction system in the ANRS (Automatic Noise Reduction System) format as a means to reduce the noise of the difference signal recorded in the UHF range to produce a rear signal. JVC cassette decks started being produced with an inbuilt

ANRS system not long after the Dolby B appeared. Although ANRS was JVC’s own technology, it operated very similarly to the Dolby B system and the two were thought to be compatible. Dolby carried out negotiations with JVC on the ANRS format in order to promote standardisation and ensure patent licencing fees, but in the end it accepted the originality of ANRS and formally acknowledged its compatibility with Dolby B. Many JVC ANRS cassette decks had NR switches labelled “ANRS/Dolby B”, indicating that there was compatibility between the two.

11.4.2 dbx

dbx is a noise reduction format developed and released by American company dbx, Inc. in the early 1970s. It started out as a high-performance noise reduction system for business machines to rival the Dolby A system. Designed to work across a wide range of frequencies and levels, its compression/expansion worked in a logarithmically linear manner. Fig. 11.7 shows input and output using the dbx format. Since any signals above 0dB are attenuated, it could compensate for any tape saturation and could produce drastic noise reduction, meaning it was superior in many ways. However, it was very difficult to incorporate the system into any popular-model tape recorders, as the circuit was complex and costly and uniform compression/expansion was carried out regardless of signal level or frequency, meaning it would be susceptible to breathing in machines with poor basic performance. An increasing number of manufacturers began to use it in high-end cassette decks due to the good sound quality and drastic noise reduction effect; to some extent, it gained a reputation as offering higher-end NR than Dolby. It gained relatively wide acceptance in the world of business machines and was often used by companies such as recording studios. While the introduction of music tapes presented no obstacle to the system, it was never put to use in consumer machines and gradually disappeared off the market.

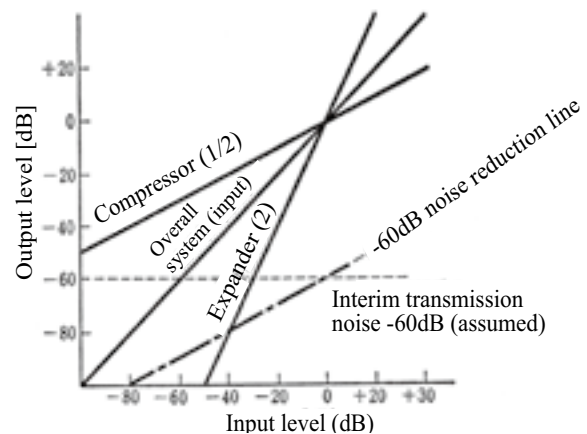

Fig. 11.7. Input and output properties using dbx format ⁽⁵⁾

11.5 Noise Reduction Development

The Dolby B, ANRS and dbx systems were incorporated into cassette decks relatively early on. While this contributed to the Hi-Fi capabilities of the Compact Cassette, as the adoption of digital audio became an increasing reality from the late 1970s onwards, the Compact Cassette had to further expand its dynamic range, in other words, increase its noise reduction effect. Every Japanese manufacturer at the time developed and released its own noise reduction system, working on its own developments as well as joint developments with manufacturers in the West (Fig. 11.1). Meanwhile, the veteran company Dolby announced the Dolby C, the successor model to the Dolby B. The Dolby C system ran two B-type operations in stages, expanding its noise reduction range to lower frequency areas, producing a noise reduction effect of 20dB or more. Comprising two B-type circuits together, as shown in the block diagram in Fig. 11.8, the C system could also operate as a B-type system by running only one phase on one circuit. Not only was it easy to switch between B and C operation, there were also obvious cost benefits to combining it all in an integrated circuit. While it offered less in terms of noise reduction and tone sensitivity compared to other formats, it performed at an adequate level to be used as a Compact Cassette noise reduction system in the digital audio era. Given the degree of familiarity with the “Dolby” name, many manufacturers deemed it beneficial to adopt the Dolby C system; thus, the Dolby C secured its place as the de facto standard system. When CDs appeared in 1982, the audio world immediately

became digitised and the Compact Cassette sound quality competition came to a standstill, although the Dolby C kept its popularity in the field of high-end machines.

This competition between NR systems prompted the development of secondary functions in cassette decks to make NR systems work more accurately, thereby playing another role in improving the performance of cassette decks. Compact Cassette noise reductions systems all worked on the basis of compressing and expanding analogue signals. The operating principle was that tape recorders had uniform recording and playback properties, that is, the signal level during recording and playback was identical and that the frequency response was even. When this assumption was disproved, there was a fear that the difference in levels would increase through compression/expansion. Any disparity in frequency response potentially meant that the NR could malfunction. While there was a certain degree of tolerance in the precision and stability of Compact Cassette machines, if different tapes were to be used, there would be subtle differences in sensitivity and frequency response, depending on the tape. To prevent this variability, the drawback of noise reduction, and to ensure high sound quality through precise operation, high end machines appeared equipped with a “calibration function” for each tape. These machines had a standard signal generator inside them and could provide level adjustment for recording and playing back each tape; the frequency response could also be adjusted according to the amount of bias. Some of these sets were operated manually, while some sets were developed that used a CPU to make these adjustments automatically.

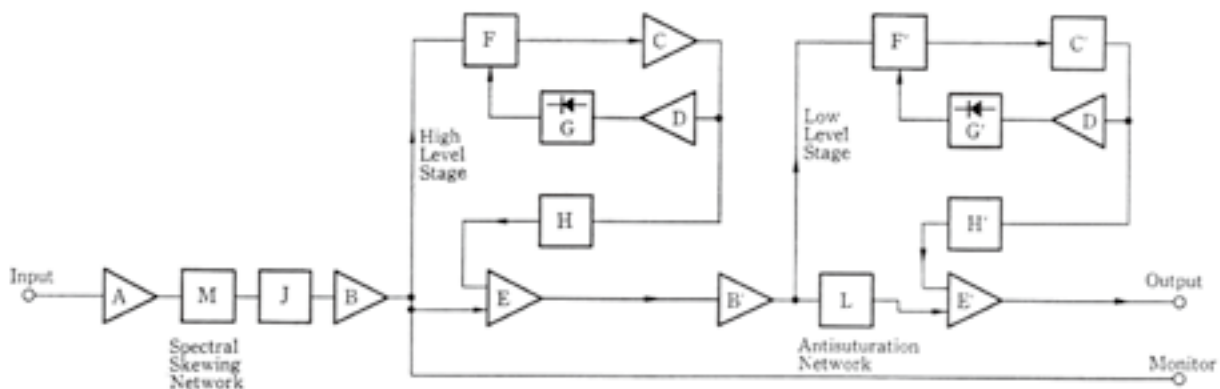

Fig. 11.8. Dolby C block diagram⁽⁶⁾

Table 11.1. Performance Comparison of Various NR Systems⁽⁷⁾

NR Format	Dolby B	ANRS	Super ANRS	DNL	dbx II	Adres	High-Com II	Super D	Lo-D Compander
Developer	Dolby Lab. (UK)	JVC		Philips (Netherlands)	dbx (USA)	Toshiba	Telefunken / Nakamichi	Sanyo	Hitachi
Local brand	Various	Victor		Hitachi / Toshiba / Nakamichi	TEAC	Aurex	Nakamichi Aiwa	Otto	Lo-D
NR Effect	10dB (5kHz+) 5dB (1kHz)	10dB (5kHz+) 5dB (1kHz)		15dB (10kHz+)	30dB+	30dB (10kHz) 20dB (1kHz) 17dB (100Hz)	20-25dB	35-40dB	20dB+
Compression expansion properties	Relative level	Variable	Variable	Expansion only (variable)	Linear	Variable	Variable	Linear	Linear
	Relative frequency	Variable	Variable	Variable	No	Variable	Variable	No	No
Frequency division	Compression rate	—	—	—	1:2	1:1.5/1:1	1:2/1:1	1:2	1:1.5
	High-level compression	No	No	No	1:2	1:1.5	1:2	1:2	1:1.5
Level detection	Frequency division	No	No	Wide-range only	Single band control	Single band control	Split in two	Split in two (48kHz)	Single band control
	Level detection	RMS	RMS	RMS	RMS	RMS	RMS	Peak response	Peak level
Level detection channel	Level detection	LR separately	LR separately	LR separately	LR separately	LR separately	LR separately	LR separately	L+R
	Emphasis	Fixed + variable	Fixed + variable	Variable	Fixed	Variable	Variable	Fixed	No
Attack time (ms)	1	1.5-2			several ms		1		High-level: fast Low-level: slow
Recovery time (ms)	300	100			Encoding 200 Decoding 400	100			200
Level matching	Required			Not required	Not required	Required	Required	Not required	Not required
Breathing countermeasures	Not required	Not required		Not required	Emphasis high-level recording	Reduce compression ratio Variable emphasis	Reduce compression ratio Bandwidth division	Reduce compression ratio Bandwidth division	Reduce compression ratio
Clipping	Fast attack time Limiter	Fast attack time			Fast attack time Weighting circuit	Weighting circuit	Fast attack time	Weighting circuit	High-level fast attack time
Other					Used in decks with good frequency response and level variations	Variable emphasis	Bandwidth split in two Variable emphasis	Bandwidth split in two	Low-level slow attack time safeguards group delay

References

- 1) Saishin Ōdio Gijutsu [Latest Audio Technology], Ohmsha, April 1991, p. 15.
- 2), 3), 4) Shirai, Tatsuro. “Waga-Sha no Noizu Ridakushon Shisutemu: Nihon Bikutā [Our Company’s Noise Reduction Systems: JVC]”, JAS Journal, 1981, Vol. 21, No. 10.
- 5) Kogure, Takuyo. “Waga-Sha no Noizu Ridakushon Shisutemu: Matsushita Denki Sangyō [Our Company’s Noise Reduction Systems: Matsushita Electric Industrial]”, JAS Journal, 1981, Vol. 21, No. 10.
- 6) Takasu, Daihachiro. “Waga-Sha no Noizu Ridakushon Shisutemu: Tiakku [Our Company’s Noise Reduction Systems: TEAC]”, JAS Journal, 1981, Vol. 21, No. 10.
- 7) 50 Years of Audio. Japan Audio Society Publishing, December 1986, p. 512.

12 | Advances in Driving Motors

12.1 Early Mechanisms and Motors

The early Compact Cassette tape recorders were released with single-motor mechanisms, aimed at maximising functional performance, downsizing and simplifying (Figs. 12.1, 12.2). Since the overall machines could be made smaller than the open-reel systems and could get by with the minimum necessary power to drive the tape, developers used low-output DC motors in them. However, the high-performance cassette deck followed on the tail of these machines and grew in popularity. To have the performance and function of serious audio equipment, these tape recorders had to meet higher standards than the small-scale machines in terms of the accuracy and reliability of the machine itself. While they still had the same tape recorder mechanisms to play Compact Cassettes, these new machines were the successor models. The early deck-type machines were intended for use in the home; many of them had the AC motors that were in standard use in the open-reel machines. When the Compact Cassette appeared, DC motors were used in toys and trivial consumer electronic goods; they had hardly ever been used in audio equipment. By contrast, there were already a number of superior AC motors designed for audio systems, having been used in record players and open-

reel tape recorders. It was also very important for record players and tape recorders to maintain an accurate rotation speed, so hysteresis synchronous motors, which could rotate in sync with the power frequency, were well suited to audio equipment.

Rapid improvements were made to the overall design of both the deck-type and portable-type machines. The main driving mechanism in both types changed from an AC motor to a DC motor, due to the development of servo motor technology to maintain a steady rotation speed and successive developments on DC motors designed to suit audio equipment. This resulted in greater reciprocal interaction: the mechanism design required the motor to be high-spec, as it was the core device; in turn, the mechanism had to be more advanced to handle the new motor. The Compact Cassette size restrictions would have been another factor, as this would have naturally played a part in determining the size of the mechanism and prompted the use of small-scale DC motors. Among other factors, suitable motors for audio equipment had to run smoothly and silently with no rotational irregularities; they had to guarantee a long operating life of at least 1000 hours under a certain load; they had to produce minimal electromagnetic noise and readily produce a prescribed rotation speed.

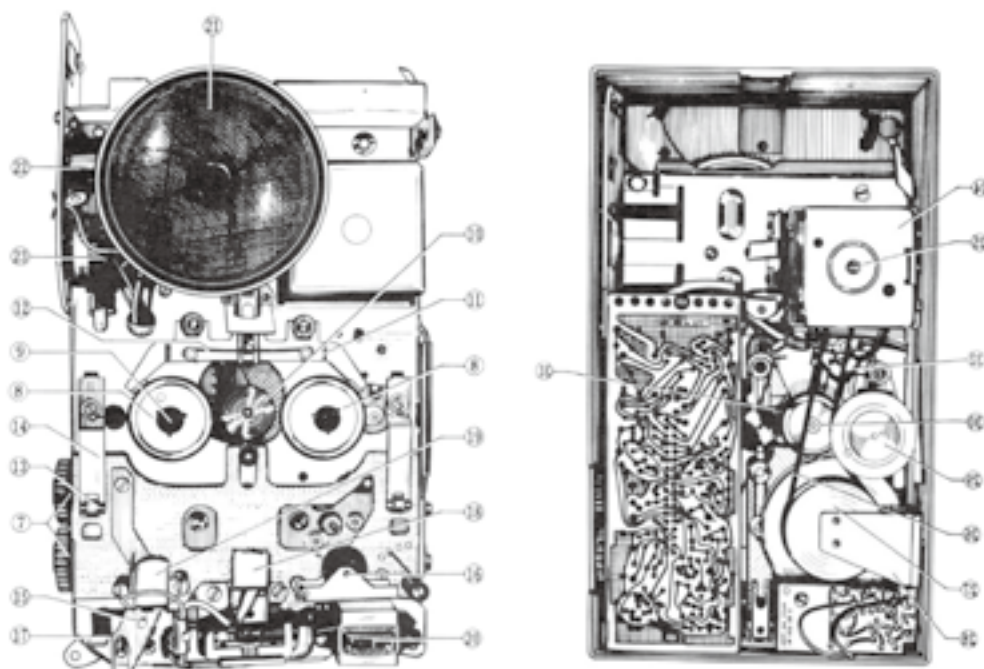

Fig. 12.1. Inside of an early cassette tape recorder⁽¹⁾

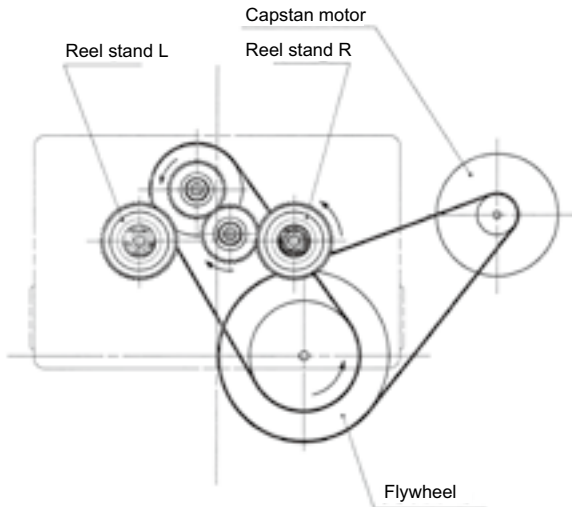

Fig. 12.2. Basic single-motor tape deck mechanism⁽²⁾

12.2 Servo Motor Development

Many of the DC motors used in the early Compact Cassette machines had mechanical governors as a means to attain fixed speeds. A mechanical governor is a switch that uses centripetal force generated in proportion to rotation speed to automatically turn the power supply to the motor on or off (Fig. 12.3). The counterweighted governor is directly connected to the motor's rotational axis; as the rotation speed increases, the centripetal force makes the counterweights move along the outer circumference, thereby braking a connection. The current stops and the rotation speed decreases. If the rotation speed drops below a certain limit, the centripetal force decreases and the connection is made; the current resumes once more. Repeated tens to hundreds of times per minute, this operation serves to maintain a fixed rotation speed. Although it is a relatively simple, low-cost mechanism, it is prone to generating electrical noise as the connection joins and breaks. Furthermore, if constant speed is a strict requirement, it becomes very complicated to regulate contact pressure and other factors, which affects the reliability and longevity of the device. While only average in performance, such motors were often used in popular-model tape recorders because they were simple and cheap.

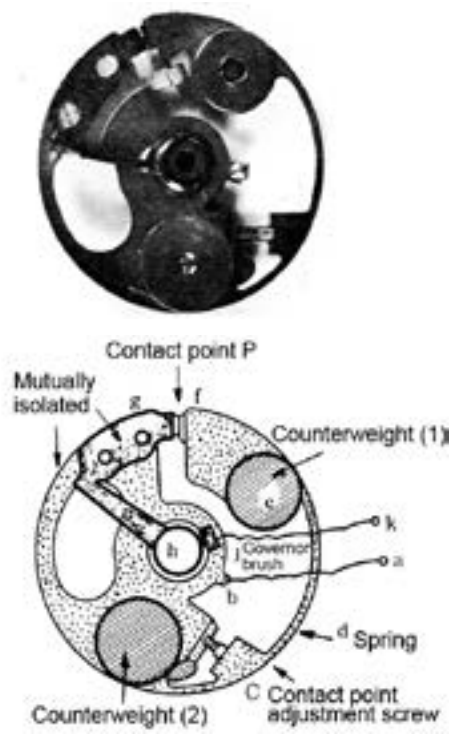

Fig. 12.3. Mechanical Governor⁽³⁾

The governor motor had limitations to the constancy of speed it could produce; it also generated electrical noise and was somewhat unreliable. In light of these factors, efforts were made to introduce servo technology, as this was capable of producing a higher-performance motor. Servo motors work by detecting rotation speed with a sensor and then using that information to perform feedback control on the driving current. A frequency generator (FG) was developed to be used as a sensor, working on the same principle as an AC generator. The FG principle comprises a multiple-pole ring magnet being rotated to induce an alternating current of a frequency corresponding to the rotation speed in a coil wound around a comb-shaped sensor. If the number of N poles is designated as N and the rotation speed as X rps, the current generated corresponds to $N \times X$ Hz. Figs. 12.4 and 12.5 show the structure and principle of FG. Fig. 12.6 shows the internal workings of an actual motor with a FG incorporated.

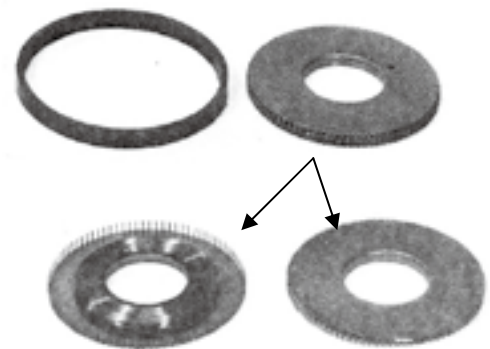

Fig. 12.4. Complete FG and comb-shaped sensor component structure⁽⁴⁾

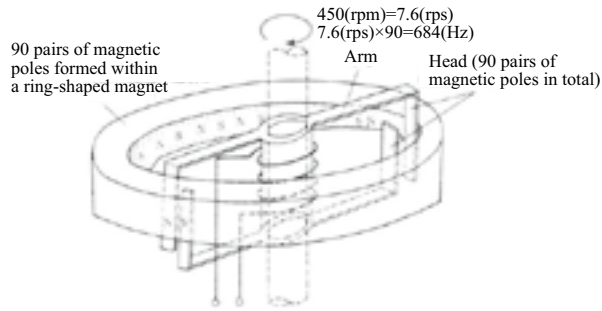

Fig. 12.5. Diagram of the FG principle ⁽⁵⁾

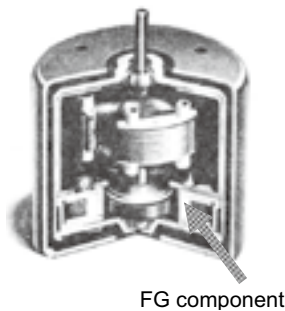

Fig. 12.6. Example of a standard DC motor ⁽⁶⁾

The size and frequency of the voltage generated are in proportion to the rotation speed and either can be used as a control signal. By increasing the number of magnetic poles, it is possible to increase the accuracy of the sensor and gain a high-frequency signal even with a low rotation speed. However, if there are an excessive number of magnetic poles, the output decreases and the S/N ratio gets worse, thus reducing the reliability of the sensor. Consequently, an appropriate FG with an appropriate output suited to the rotation speed used should be incorporated into motor design and assembly.

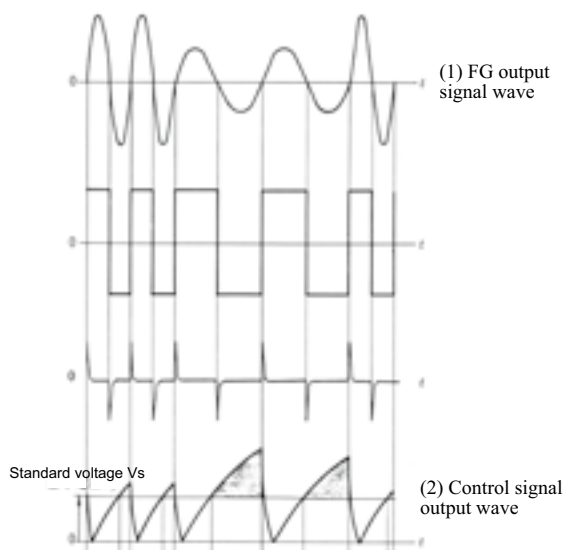

Fig. 12.7. FG output signal processing (section) ⁽⁷⁾

The FG output signal varies as shown in Fig. 12.7 (1) as the rotation speed varies. It takes the form of a combination of AM modulation, in which the amplitude changes in proportion to the rotation speed, and FM modulation, in which the frequency changes in proportion to the rotation speed. The AM control signal method was often used in devices where cost was a major factor, as it could be achieved with a relatively simple electronic circuit, but it was not capable of demonstrating the full capabilities of the highly-anticipated FG. By contrast, the method shown in Fig. 12.7 used to achieve a control signal through FM was called frequency control. It was often used in high-end machines such as tape decks as, although costly, it was fully capable of high servo performance.

Cassette deck mechanisms started out as basic, single-motor devices and developed into two-motor devices with independent motors for driving the reels, as shown in Fig. 12.8. This format enabled the dedicated use of the capstan-driven motor, which was key to precise tape feeding, making it possible to achieve high performance. A “direct drive” type was also developed, which had the capstan directly connected to the motor axis.

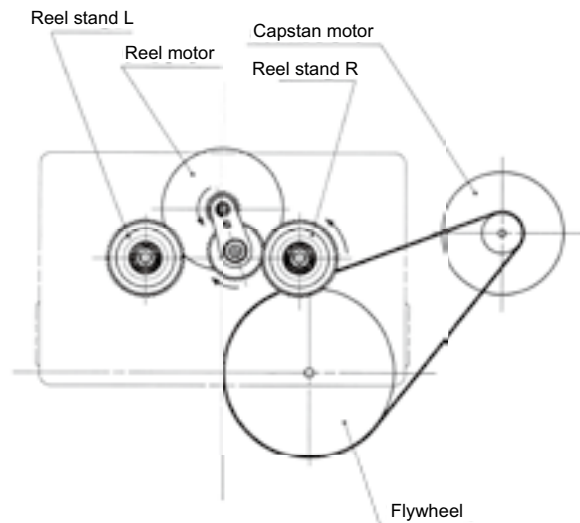

Fig. 12.8. Basic two-motor tape deck mechanism ⁽⁸⁾

12.3 Direct Drive Motors

The direct drive system, with the capstan directly connected to the motor axis, was suited to audio equipment, as it could produce a low rotation speed with minimal vibration or operating noise. It was also simpler and more reliable than other indirectly-driven systems, which used a power transmission mechanism such as a belt or idler as a reduction drive for the capstan. However, indirectly-driven systems allowed the rotation speed to be set at a more efficient rate and made it easier to maintain driving torque through deceleration. They were likely to be used in small,

inexpensive motors, giving a greater freedom of choice in motor selection. On the other hand, since intermediary components were used in power transmission, the overall structure of servo driving systems was more complex, making it a little more difficult to operate the control system to its full capacity. Direct drive systems were quite the opposite: they were mechanically simple and readily allowed accurate servo control. A large-diameter flywheel could not be used where there was a low rotation speed, or in a Compact Cassette tape recorder, so moments of inertia were not a reliable option. It was therefore necessary to design the motor making the output frequency of the FG that detects the capstan rotation speed as high as possible, widening the servo bandwidth and making the rotation as smooth as possible. This required a brushless motor, which, although it was not cost-effective, was designed for use in high-end tape recorders.

Open-reel machines had quite spacious mechanisms, with a greater degree of freedom in terms of the drive system design and choice of motor; hardly any of them used a direct drive system. Direct drive motors were probably first developed for use in record players. Matsushita developed a low-speed brushless motor for record players quite early on; this “direct drive” technology was then able to be used in the smaller cassette decks at an early stage as well. In 1970, the RS-272U (Fig. 12.9) became the world’s first cassette deck with an inbuilt direct drive system.



Fig. 12.9. Matsushita RS-275U (1970) ⁽⁹⁾

While record players already held the dominant position as the main audio playback machines, a flurry of new technology and product developments after the Second World War for all components accompanied major breakthroughs such as LP records and stereo-capable machines, making the record player the most important item of home audio equipment. For instance, while manufacturers in the West had always supplied the best pickup cartridges, arguably the most essential component for playback, many cartridge manufacturers appeared in Japan from around 1960 and began to produce cartridges that were just as good as their counterparts made in the West. In particular, Denon, which had played an active role in the disc-style recorder industry before the war, worked

with the NHK Science & Technology Research Laboratories to produce the DL-103. Although they developed this cartridge in 1964 as a business-use device for use in FM stereo broadcasting, it brought in a lot of interest from audiophiles who were impressed by the high sound quality of the FM stereo broadcasts. The MC cartridge was released in 1970 for consumer use and became well-loved throughout the world as a high-performance device. Incidentally, it is still being sold to this day. As well as developments to the components in the transducer unit, such as the cartridge and the tonearm, developments were also taking place on the turntable drive mechanism, with remarkable improvements being made in performance, such as progressing from the idler drive to the belt drive and introducing servo technology. Matsushita developed a low-speed brushless DC motor quite early on to be used in record players, announcing its brushless DC direct drive phono motor technology in 1969. While Sony also developed a direct drive phono motor around the same time, this was an AC motor. Although Matsushita was the first to announce direct drive technology, Sony released the TTS-4000 (Fig. 12.12) and the PSE-4000 record player system incorporating it in 1970, about one month earlier than Matsushita released the SP-10 (Figs. 12.10, 12.11). The world’s first direct drive phono motors appeared one after another in Japan. For the first time, original Japanese technology was appearing on the world audio market.



Fig. 12.10. Matsushita direct drive turntable SP-10 (1970) ⁽¹⁰⁾

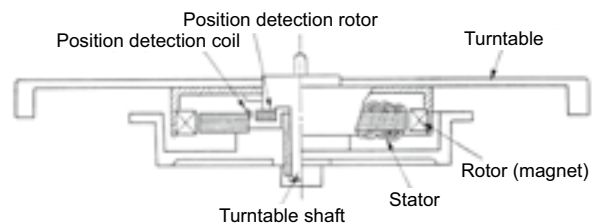

Fig. 12.11. Cross-section of a SP-10 DC direct drive phono motor

12.4 Development of the DC Brushless Motor



Fig. 12.12. Sony AC servo-type direct drive phono motor TTS-4000 (1970)⁽¹¹⁾

Armed with the DC direct drive motor, Matsushita was able to take the top share of the world record player market. It was also able to apply the same low-speed DC servo motor technology to make a direct drive system for the tape recorder, thereby creating the world's first direct drive cassette deck. It also applied the technology to a single-capstan, closed-loop, open-reel machine, releasing the high-end, high-performance RS-1500U (Fig. 12.13) in 1976. Fig. 12.14 shows internal and external views of the direct drive motor used in the RS-1500U.



Fig. 12.13. Matsushita RS-1500U (1976)⁽¹²⁾

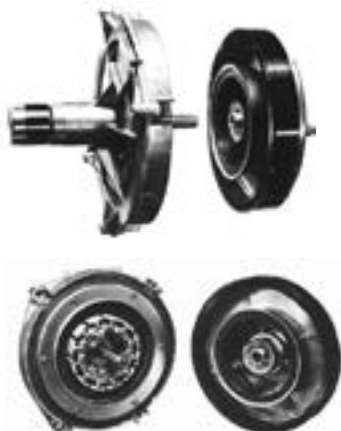

Fig. 12.14. RS-1500U capstan motor (internal and external views)⁽¹³⁾

As AC motors used induced currents and eddy currents, induced in a rotor by a magnetic field, they had greater torque uniformity. While this was good for sound, it meant they lacked controllability. By contrast, DC motors were more controllable, but they had greater fluctuations in torque caused by the timing with which the magnetic poles turned to keep the motor rotating. To prevent this required increasing the number of magnetic poles, thereby evening out the torque generated by multiple poles. Accordingly, although the DC motor presented more manufacturing issues than the AC motor due to greater complexity in the field winding structure, it was easier to increase its efficiency. As the DC motor control circuit did not have to deal with large AC currents, it was very compatible with transistor circuits. It lent itself to being made smaller and lighter, making it a good candidate for small-scale devices. In fact, DC motors started being used in most of the audio-visual equipment that was brought out after this. In 1970, Sony released the world's first direct drive phono motor using AC to ensure rotational torque stability. While this was used in basic player systems for a time, the DC motor steadily became the standard.

With the move to DC, studies began on how to suppress the fluctuation in torque occurring with polarity changes in the magnetic field. A driving method was developed that generated torque in a theoretically linear manner rather than increasing the number of magnetic poles. Generally, the torque generated by a DC motor corresponds to the product of the magnetic flux density (in the gap) between the rotor and the stator and the current flowing through the coil interacting with the magnetic flux in the gap. Where the rotor is a thin, cylindrical magnet with multiple poles magnetised in a sine wave in the radial direction, the stator coils are positioned so that the two sets of poles have a phase difference of 45° . A Hall effect sensor is used as a flux detector to ensure that the current flowing through the two coils corresponds to the magnetic flux of the rotor. When the current is linearly altered rather than switched, the torque generated by the first coil-magnet pair corresponds to the square of $\sin \theta$ (where θ represents the turning angle of the rotor). The remaining coil-magnet pair has a phase difference of 45° , so the torque generated there corresponds to the square of $\cos \theta$. In theory, the torque then remains uniform, since the torque generated between the two corresponds to $\sin^2 \theta + \cos^2 \theta = 1$ (Fig. 12.15). This type of motor is called the BSL (Brush & Slotless) motor; it was developed to be the main motor used in mid- to high-end audio equipment. First used as a direct drive phono motor for record players, its scope of use soon expanded to cassette deck standard motors (Fig. 12.16) and direct drive capstan motors. An OTM (one

sensor two phase) type was also developed, which combined this with a pole detection sensor; this arrangement was used to slim down the Walkman.

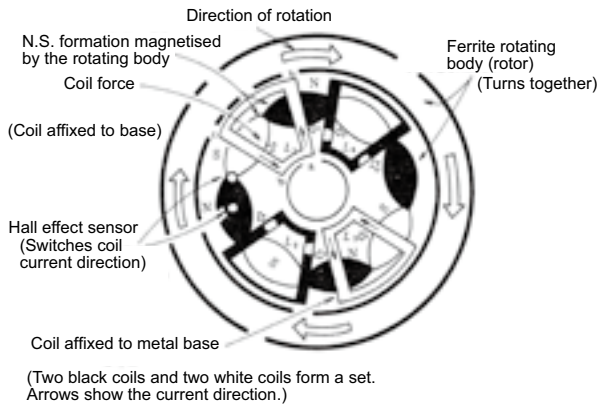

Fig. 12.15. Diagram of the BSL motor principle⁽¹⁴⁾



Fig. 12.16. Standard BSL motor

12.5 Coreless Motors for Portable Machines

Small-scale tape recorders made good use of the size of the Compact Cassette, developing into far more fascinating products than had been seen in the open-reel era. This new type of small-scale tape recorder focused on being small, lightweight and easy to use rather than being Hi-Fi capable. They were also mostly battery-operated, so electricity consumption was a major factor for consideration. Reducing the electricity consumption of the motor was a very significant issue. To start with, standard iron-core brushed DC motors were used in small-scale tape recorders. Motors were selected on the basis of being as small and as

simple as possible, with mechanical governors for speed control and back EMF control. However, the standard iron-core motors were limited in terms of their size and electricity consumption. It was deemed necessary to increase the performance of the set with each enhancement in functionality. Small-diameter, coreless motors were developed around this time and began to be used in handheld tape recorders. The overall performance of the motor rapidly improved, not only in terms of electricity consumption, but also in terms of less mechanical and electrical noise and greater reliability. This greatly boosted the product value of the small-scale tape recorder.

While the rotor in an ordinary small-scale DC motor consists of a coil wrapped around a core, the rotor in a coreless motor consists of a cylindrical, “cage-like” coil; this is also called a moving coil (MC). As no eddy-current loss (core loss) occurs when the rotor turns, it is theoretically more efficient. Other changes were incorporated into the design to make it more efficient overall, such as using rare-earth magnets to generate torque even with small diameters, or narrowing the space in which the rotor turns to increase the magnetic flux density. These were also produced with inbuilt FGs and also used in servo control (Fig. 12.17). For more information on small-scale, handheld devices using small-scale coreless motors, see the discussion in Chapter 6 on product developments related to the Walkman.

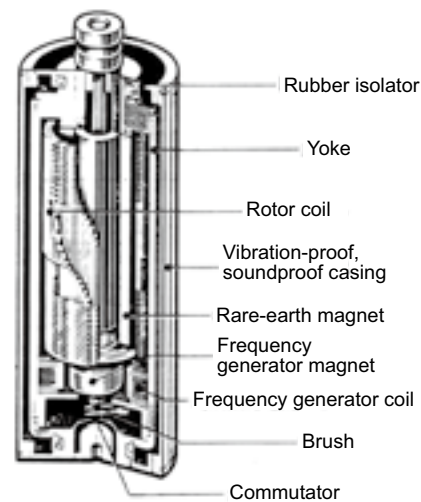

Fig. 12.17. Structural diagram of a small-diameter coreless motor

References

- 1) Mori, Yoshihisa, et. al. Onkyō-Gijutsu-Shi [History of Sound Recording], Tokyo University of the Arts Press, March 2011, p. 91.
- 2) Saishin Ōdio Gijutsu [Latest Audio Technology], Ohmsha, April 1991, p. 171.

- 3) Tēpurekōdā no Kiso [Tape Recorder Basics]. Sony (Inc.) Technology Education Center, May 1985, p. 173.
- 4) Ibid., p. 209.
- 5) Ibid., p. 209.
- 6) Ibid., p. 207.
- 7) Ibid., p. 217.
- 8) Saishin Ōdio Gijutsu [Latest Audio Technology], Ohmsha, February 1995, p. 171.
- 9), 10), 12), 13) Provided by Panasonic Corporation.
- 11) Provided by Sony Corporation.
- 14) Tēpurekōdā no Kiso, p. 220.

13 | Towards the “Headphone Stereo”

13.1 Popularity of Radio and Home Audio

Thus far, listening to music on audio equipment had been a pleasure to be enjoyed at home. Ever since Edison and Berliner invented the phonograph and gramophone, music had been listened to in the living room, recorded on the medium of records. Of course, venues such as restaurants and bars also used music products to entertain their guests, providing background music or music for dancing. Certain shops also specialised in providing certain styles of music for listening, such as jazz or classical. In any case, whether it was played for the purpose of listening to “good music” or for creating a “pleasant environment”, it was always played indoors on large, bulky equipment.

Radio broadcasts began in the 1920s and rapidly gained popularity throughout the world, starting in the West and spreading to Japan. Broadcasting was done through cutting-edge wireless technology; it was a ground-breaking means of transmitting information to the masses and people became enthralled by radio news broadcasts. Radio broadcasts could also transmit music, something that was absolutely impossible through paper media such as newspapers, so it was not surprising that listeners readily welcomed musical broadcasts from the beginning. While the gramophone and SP records had already enjoyed some degree of popularity before radio broadcasts began, playing music had not really become a true form of mass entertainment, as one record could only play for ten minutes or less and gramophones and records were expensive. When radio broadcasts began, the record industry was afraid that radio was encroaching on its domain; however, the outcome was the complete opposite: repeated radio programmes were very popular with listeners and prompted a major increase in gramophone and record sales. Trend-setting radio broadcasts and records for playing music had a mutually beneficial effect on each other, creating a “home audio” culture. While pre-war radio broadcasts in Japan focused on providing information, such as news broadcasts, after the war there was a growing interest in musical broadcasts, inspired by the AFN (American Forces Network)* for American troops in Japan. Not long after the war, the AFN became a major presence in Japan, having given rise to a large number of music fans and audiophiles. At this time, the AFN was drawing on disc-style records recorded in the United States for its source of music; Japanese audio engineers were profoundly inspired by listening to the tremendous radio sound quality afforded by American recording and broadcasting technology, the best

in the world. Commercial broadcasting began in 1951 and further developments continued on music broadcasting in Japan.

* AFN: Broadcasts for American troops, known as the FEN (Far East Network) in Japan until 1997.

13.2 Higher Quality Radio Broadcasts

LP records were released in Japan in 1951. These records were highly regarded by audiophiles not only for their longer playing time, but also for their high-quality sound. High-quality music playback became popular immediately, resulting in a growing dissatisfaction with the quality of radio broadcasts. At the time, radio broadcasts were medium-wave AM broadcasts. While various efforts were made to raise the quality, such as introducing stereo broadcasts using two AM stations, as television broadcasts gained in quality, AM radio music programmes ended up being mainly so-called “disc-jockey” programmes intended for car radio or portable radios. High sound quality was delegated to FM broadcasts.

By 1940, there were already around 30 FM radio stations operating in the United States. FM broadcasting began to spread in earnest from 1955, when the FCC (the United States Federal Communications Commission) approved the transmission of news and background music using FM multiplex broadcasting sub-channels. In Europe, West Germany planned to cover the entire country with FM, having had its medium-wave frequency allocation reduced following its defeat in the war. These broadcasts began in 1945 and soon their superior sound quality attracted the attention of countries such as the United Kingdom and France, thus spreading the popularity of FM broadcasting. In 1957 and 1958, the NHK opened experimental stations in Tokyo and Osaka, while experimental commercial station FM Tokai started broadcasting in 1960. The Japanese had greater hopes for high-quality broadcasts than the noise- and interference-ridden broadcasts in the West; Japanese broadcasters set their sights on Hi-Fi music broadcasts from the start. In 1956, the 45/45 stereo LP record took hold in the industry, but stereo records were very highly priced for everyday users at the time. Many audiophiles eagerly awaited FM stereo broadcasting. On 17 December 1963, the NHK made its first FM stereo broadcast. The first song was Mozart’s Symphony No. 40, performed by the Vienna Philharmonic Orchestra and conducted by Herbert von Karajan. The preparations for FM broadcasting in earnest had thus been steadily laid. From 1969 to 1970, the NHK and

commercial broadcasters began proper broadcasts, ushering in Japan's FM age in earnest.

13.3 Music Broadcasts and Recorders

The commencement of proper FM broadcasting coincided almost perfectly with the appearance of Compact Cassette tape recorders. These tape recorders received much attention as being capable of recording high-quality musical broadcasts. The NHK and many other interested parties had put a lot of effort into the sound quality of FM broadcasts, while Japanese audio manufacturers had competed ruthlessly to develop the receivers. As a result, FM broadcasts were a fairly high quality source of music. At the time, high-end, open-reel tape recorders were considered suitable for recording music and the use of a deck-style machine in conjunction with stereo equipment became a favourite among audiophiles. Since FM stereo broadcasts have a 19kHz stereo pilot signal and acoustic properties extending to approximately 15-16kHz, (in terms of specifications) the open-reel machines had to perform in four-track stereo at 19cm/s. Reverse machines were also well-received, capable of long, continuous recording of music broadcasts. Open-reel decks reached a height of function and performance in the early 1970s, when the so-called unattended recording function was added to record desired programmes from FM broadcasts. By contrast, the Compact Cassette served as a memo recorder and was thought to be incapable of proper Hi-Fi music recording. However, its ease of use, potential for downsizing and firm position as the de facto standard were enough to show promise for the future. Efforts were redoubled to produce technology capable of high quality sound and somehow rival that of the open-reel machines. Within a short time, the Compact Cassette had earned its own place as a serious piece of audio equipment. (See Chapters 8 to 12.)

13.4 Transition towards Personal Audio

Another factor contributing to the popularity of radio broadcasts was the personalisation of the audience. Listening to the radio or playing music on records was entertainment enjoyed in the living room together as a family. For a long time, it was normal to have one piece of audio equipment per household. When stereos started becoming popular in Japan, most of them were bulky pieces of household furniture, whether they were ensemble devices or separate devices. However, Japan took the lead in downsizing this equipment using transistors, opening up a market for portable audio systems quite early on. Once these portable radios became affordable in the 1960s, disc jockey programmes in the form of late-night broadcasting became immensely popular with

the younger generation; programmes aimed at these young people introduced new musicians and the latest pop music from overseas, playing a major role in the spread of music culture and the expansion of the record industry. There was a growing interest in FM and FM stereo broadcasts from users accustomed to listening to music on small-scale radios seeking a better and more impressive sound. While they preferred high-quality radios and stereos, the price of proper audio equipment was too high for young people to personally afford.

Consequently, although music was growing in popularity, young people could not afford records and audio equipment. This all changed with the appearance of the "radio cassette". This machine could have been called a modern gramophone – a device incorporating a small-scale Compact Cassette tape recorder and a radio capable of FM reception together in one unit with an inbuilt amplifier and speaker. This concept and the attractive price meant that it received tremendous backing as a personal audio device for young people. It could reliably record FM broadcasts onto Compact Cassette and play them back quite simply for repeated listening. Such ease of use was one of the major advantages to this device. It continued to develop into a serious piece of sound equipment, successively incorporating stereo capabilities, loud volume, double cassettes and CDs. The progress from radio to radio cassette player was one clear step in the personalisation of audio. The image of audio equipment for individual use shifted from that of tape recorders for recording or radios for information gathering to that of devices for enjoying music by oneself. The radio cassette player progressed into a small-scale personal combo (a stereo for a child's room); music recorded on Compact Cassette could be built up into a wealth of soft assets at the user's disposal.



Fig. 13.1. Matsushita RX-D30 stereo radio cassette player (1981)⁽¹⁾
The first double-cassette type

13.5 Creation of the “Headphone Stereo”*

The Compact Cassette was rapidly improving in performance and becoming established as the main tape recorder for music. Users were building up collections of recorded music at their disposal. Music appreciation was becoming more personalised in style and individuals increasingly had exclusive use of their own equipment. The idea of a “headphone stereo” clearly fulfilled people’s aspirations to “listen to music, anytime, anywhere” and would certainly have a decisive effect on the audio environment of the future. When these devices came out, some people viewed the idea of a tape recorder that could not record as being half-finished. However, the Compact Cassette tape recorder had an acceptable level of performance and sound quality and happened to serve the purpose of having “music anytime, anywhere”. A tape recorder becoming the first of these “headphone stereos” was clearly quite by chance, and the concept of portable audio devices continued to change and develop as advances were made in CDs, MDs, semiconductors and media. The greatest success factor was in the planning of a product that enabled people to “listen to music, anytime, anywhere”. The goal to achieve a portable device came down to the matter of making a simple machine that was small, lightweight and low in energy consumption. As there was a pre-defined tape size and mechanism for the Compact Cassette, various mechanical innovations and clever circuitry had to be incorporated into the tape “headphone stereo”, but developers finally managed to achieve the ultimate in downsizing.

* “Headphone stereos” refers to a general category of devices perhaps better known by the pet name for the first model: the “Walkman”. The term is used without distinction in this report.



Fig. 13.2. Sony TPS-L2 (1979) The first Walkman ⁽²⁾

In 1989, Akio Morita, the chairman of Sony Corporation at the time, wrote a thought-provoking passage in a commemorative publication celebrating the Walkman’s tenth anniversary, outlining what sparked the creation of the Walkman, the planning behind it, the naming of it and other matters. The passage is reproduced below for reference.

Reprinted from “Walkman Ten-Year Anniversary Publication”, Sony Public Relations Office, ed. (1989)

Walkman a Success in Product Planning

Akio Morita, Chairman of Sony Corporation (at the time)

Was it 1978? One day, Mr. Ibuka came into my office carrying a remodelled cassette player and a pair of headphones and said, “I wonder if you could listen to a stereo while you’re walking.” At the time, stereos and headphones were too big and heavy to listen to while walking. But when I listened to the sound on Mr. Ibuka’s remodelled player, there was definitely something better about it than listening to music through a speaker. You could also listen to it by yourself. I thought, “Well, this is quite fun!” After that, I started thinking about where people listened to music. Young people had stereos in their rooms, cars had car stereos—but you couldn’t listen to music while walking down the street. I thought of how I had seen people from time to time walking along carrying a radio cassette player with them. “Young people want to listen to music all the time,” I thought. I started thinking with more interest about the cassette player Mr. Ibuka had brought in to me.

Mr. Ibuka had also suggested remodelling the popular “Pressman” cassette recorder and taking out the recording unit and speaker. I asked everybody, “Wouldn’t it be more fun if we could make a stereo much lighter?” Most of them said, “That would never sell.” There was no support from anyone in our acoustics division either. This was because “we had never sold a tape recorder that could not record”. But when I thought about it, we sold a lot of car stereos and they could not record. So I thought, “All you need when you’re walking is a player. Let’s definitely make one.” I got serious and gave the order to build a prototype. Super-express development got under way, with the strict aim of launching it on 1 July 1979.

During that time, I was thinking, “We have to come up with a good name for it.” One day, when I came back from a business trip, Mr. Kuroki, who was head of the Product Planning Center at the time, told me, “We’ve decided on the name ‘Walkman’.” “Walkman? That’s an odd name. Aren’t there any better names than that?” I asked. “Sorry, it’s too late. All the packaging and posters say Walkman, so we can’t change it. Please, will you accept it?” was his reply. “In that case, we can’t do anything about it,” I said. It went on sale on 1 July 1979 under the name of “Walkman” (TPS-L2). Of course, at the time, we had no idea it would become such a big business. I did, however, have some confidence and thought to myself, “We can do this.” This was because I knew that young people could not do without their music. Another reason was my own home situation: my children were always pounding the stereo, but if they had this kind of device, I could have some quiet in the house!

When we tried to market it overseas and took it to SONAM

13.6 Advances in the Walkman

(Sony Corporation of America), they said, “‘Walkman’ is weird – it’s not English. We’re not going to use that name.” The name SONAM came up with was “Soundabout”. I thought, “That’s a strange name, but we’re selling it in English-speaking countries, so let’s go with what the people in those countries say,” and decided to market it with that name in the United States. But then Sony UK said, “‘Soundabout’ is no good!” The English have a certain pride in being the originators of their language and they were not satisfied. So in England, the product was marketed as the “Stowaway”. I didn’t really know what this meant, either, but when in Rome, do as the Romans do.

However, the Walkman got very popular in Japan and visitors from other countries would buy them to take home as keepsakes. As this happened, the name “Walkman” started becoming known overseas. The name was easily understood by non-English-speaking people and use of the name started spreading throughout the world. So I decided, “If that’s the case, let’s just call it ‘Walkman’ everywhere in the world.” I gave the presidential order (I don’t really like that word) to change the name to “Walkman” in the United Kingdom and the United States as well, uniting the “Walkman” across the world.

The Walkman soon became a global hit and we put out new models one after another. The appearance of the Walkman changed the way people listened to music, which had a major impact on the world. I know that when other companies later put out their own stereos with headphones, everyone called them Walkmans as well.

When I was awarded the Albert Medal by the United Kingdom Royal Society of Arts in 1982, I said in my speech that “although Sony has created various new products, we are actually not limited to manufacturing products. We also innovate with words and have made ‘Walkman’ into an English word.” I was given a standing ovation! But what made me happiest of all was when “Walkman” appeared in the Oxford English Dictionary, the most authoritative English dictionary in the world.

This means that “Walkman” has been recognised as an English word. In the past ten years, we have given the world 50 million Walkmans, a new word and a way to listen to music that they didn’t have before. I think we can be very proud of that.

The brilliance of the Walkman is in its product planning. Cassette players and headphones already existed. However, what made the Walkman such a hit was the immense creativity in the product planning. While new inventions and discoveries are important, the Walkman has proved that if we have the sense to come up with a completely new product using existing technology, it can develop into an entire industry of its own.

The first “headphone stereo” that appeared under the name of “Walkman” was a handheld TCM-100 recorder remodelled into a playback machine. While opinions were divided as to whether it would sell or not, product developers adopted a design that took full advantage of existing products to reduce the risk. Since the same casing was used, the design was almost exactly the same in outward appearance as existing models, except for the blue exterior, which drew attention to the device’s new image. The accompanying headphones were a new, small, lightweight type that had been developed and commercialised at the same time. Marketed this way, there was overwhelming support for the product and it became wildly popular in no time. With the huge success of the TPS-L2, planning immediately started on new dedicated-playback models, aimed at coming up with an original design that would fully embody the “headphone stereo” concept. When the Walkman came out in 1979, the market for standalone, small-scale tape recorders was smaller than the radio cassette player market; there had been no investment in the development of dedicated personal devices, so existing devices had to be used for design miniaturisation and design support. In 1981, the second “Walkman” WM-2 (Fig. 13.3) was launched. This monumental model was the first to be designed exclusively as a Walkman, expressly embodying the “headphone stereo” concept and showing the way of the future. Competition then ensued between many other manufacturers as well as Sony to develop a product that was “smaller, lighter and played for longer”. The “headphone stereo” fundamentally changed the way people listened to music.



Fig. 13.3. Sony WM-2 (1981) ⁽³⁾

The first Walkman specifically designed as a “headphone stereo”

13.7 The challenge of miniaturisation

Once headphone stereos had gained popularity, fierce competition ensued to further enhance what were the portable device's most appealing features: small size and light weight. Since the tape size was already predetermined, the devices could not be made any smaller than this. However, one goal was to make a device that was the same size as the case that the tape was put into, but this size was absolutely impossible to achieve using existing tape recorder designs. The greatest obstacle to making a tape player the same size as a tape case was the size of the motor and the battery. Sony's challenge was to make full use of the characteristic properties of a dedicated playback machine to make the ultimate small-sized machine. Compact Cassettes had a difference in thickness between the area into which the heads were inserted and the area where the tape was wound. This difference was around 1.5mm on each side. The first idea was to put the motor into this area, so an ultra-thin, dedicated brushless motor was developed. The standard design had two AA batteries; however, the developers made a detailed study of the magnetic circuit in the motor and other areas and perfected a design that could operate on one AA battery. Of course, this required a new amplifier design that could run on 1.5V. Even though there was only one AA battery, it was no simple task as to where to put it. This is where the design capitalised on the characteristic properties of a dedicated playback machine: the solution was to store the battery where the erase head would have gone (Fig. 13.5). While this design achieved the ultimate in downsizing, it meant the unit where

the head was mounted, including the battery compartment, had to be pulled out in order to load a tape and some people would have inevitably thought of the device as a bit of a gimmick. However, the cassette-case-sized Walkman WM-20 (Fig. 13.4) was launched in 1983, and made a huge impact with its size. It was truly an epoch-making point in Walkman miniaturisation history.

The ultimate miniaturisation challenge was to make the perfect cassette-case-sized machine, even though it was not actually possible to make a machine the exact same size as a cassette case, as the mechanism protruded a little when in use. The AA battery was a constant hurdle to downsizing, so developers worked on a new, thin, rechargeable "gumstick battery". They also worked on other developments to downsize individual components, such as developing new, special-shaped heads that were smaller in size. The expansion of the "headphone stereo" market and the significant development investment that was being put in meant that it was economically worthwhile to work on these components. This created a virtuous cycle in which developers actively worked on new components, which in turn increased the appeal of the overall product. The WM-101 (Fig. 13.6) was released in 1985. Loaded with these new components, it truly was the size of a cassette case, marking the end of the size competition (Figs. 13.7, 13.8). Progress continued on the Walkman in various ways, such as improved function and performance, increased variation in models and more advanced designs. For a long time, it remained the favourite choice of portable audio device, while the cassette deck remained the machine of choice for recording on Compact Cassettes.



Fig. 13.4. Sony WM-20 (1983) ⁽⁴⁾
The first cassette-case-sized machine

Basic performance improvements continued on the cassette deck and new technology standards were set and standardised for it, meaning that it now could record to a very high level of quality despite the strict specifications in place. Developers had made good use of the characteristic nature of dedicated playback machines and focused their efforts on making the “headphone stereo” smaller, which added to its product appeal. Of course, the success of the “headphone stereo” was undeniably the very concept itself, which fundamentally changed the way people listened to music.



Fig. 13.5. WM-20 structure ⁽⁵⁾



Fig. 13.6. Sony WM-101 (1985) ⁽⁶⁾
The first machine to have a gumstick battery

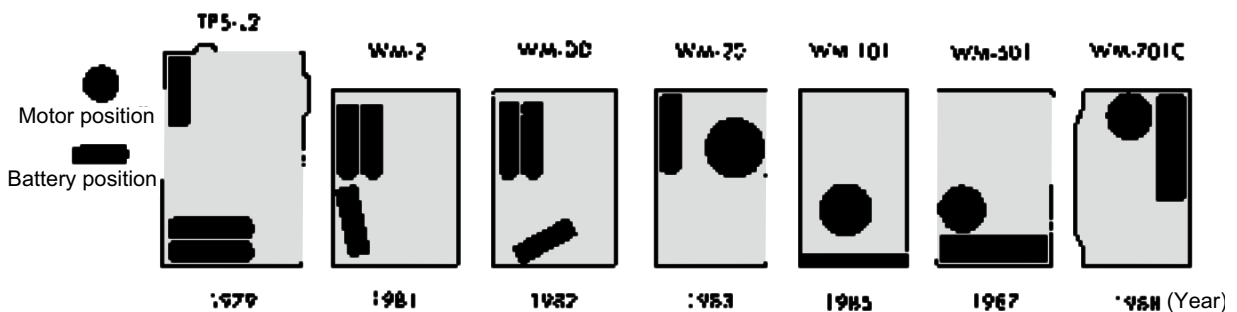

Fig. 13.7. Changes in Walkman motor and battery positions ⁽⁷⁾

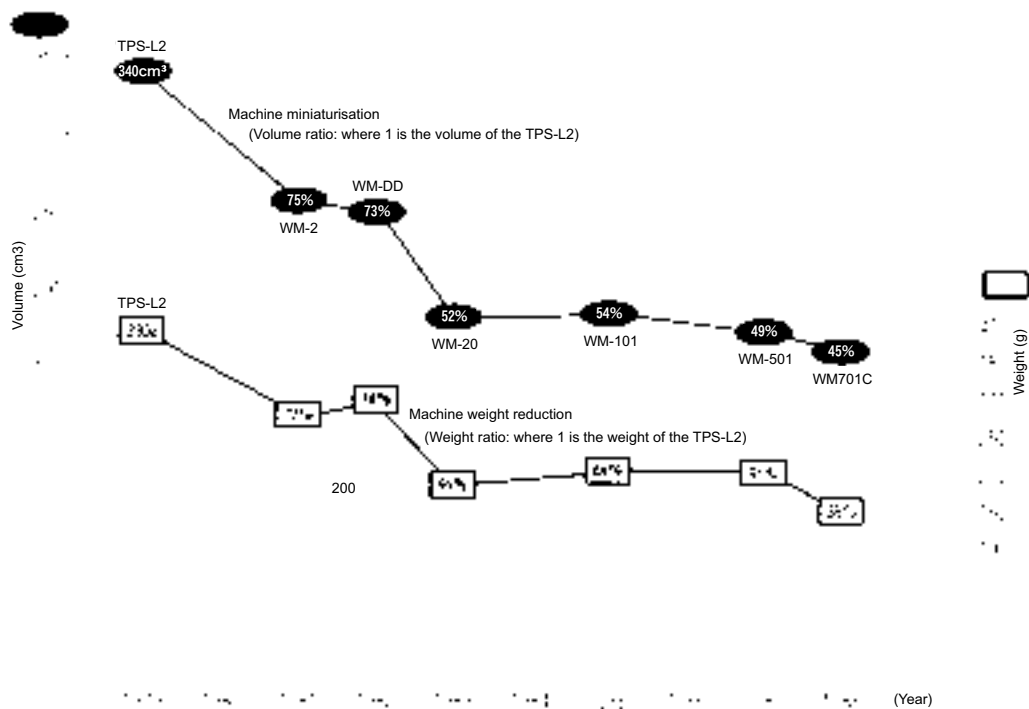

Fig. 13.8. Progress of making the Walkman smaller and more lightweight ⁽⁸⁾

13.8 Production Innovation

Since the creation of the Walkman, many of the costs involved making it smaller and more energy efficient as well as improving its sound quality and other functions and performance. This work and its strong product appeal meant that it had remained relatively highly-priced. While the high-performance, small-scale, sleekly-designed models were well received in Japan, the structure of the overseas market meant that cheaper machines would sell better, even though they were slightly bigger and had fewer features. Accordingly, lower-priced machines, produced by latecomer manufacturers, continued to occupy a large share of the market. Around the mid-1980s, Sony decided to work on a product that was competitively low-priced and launched its “P-Project”, aiming to create a Walkman after the manner of disposable cameras (also called “throwaway cameras”), which sold for ¥980.

In an all-out cost-cutting move, the company discarded its existing system of assembling mechanisms and electronic circuit units separately and then putting them together. Instead, it devised a system of directly incorporating the mechanism unit onto a printed circuit board and dispensing with the mechanism chassis. This system was a success. Other success factors were the use of a lot of plastic parts and the fact that this system used around half the usual number of parts. The company also achieved a more streamlined assembly process, with a one-way automated assembly design that involved four mechanisms being made on one printed circuit board and then separated afterwards to create

the final product. This approximately halved the usual cost, thereby boosting the line-up of low-priced products aimed at the global market with these domestically-produced products.

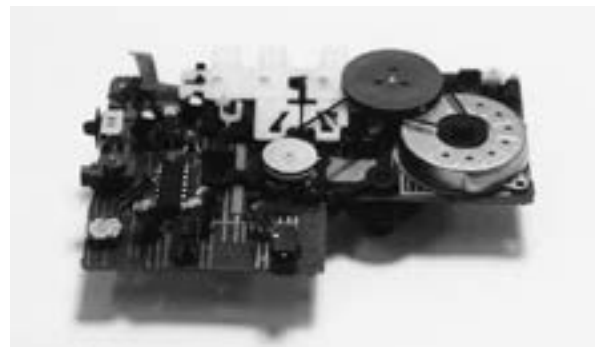

Fig. 13.9. P-Project mechanism ⁽⁹⁾

References

- 1) Provided by Panasonic Corporation
- 2), 3), 4), 5), 6), 9) Provided by Sony Corporation
- 7), 8) “Walkman Ten-Year Anniversary Publication”, Sony (Inc.), 1989.

14 | Invention of Digital Audio Tape Recorders (DAT)

14.1 Dawn of Digital Audio

Major technological developments took place on the Compact Cassette throughout the 1970s and 1980s and it finally reached a point of completion as a magnetic recording system that performed adequately for consumer use. The appearance of the Walkman in 1979 rapidly boosted the usefulness of the Compact Cassette, making it a vital part of the establishment and development of a new genre of audio products: portable audio. At the same time, tangible results were being seen in the development of practical applications for digital audio and it was considered a matter of course that Compact Cassette systems would also progress to being digital. The digitalisation of audio started with the development of magnetic tape recording systems and the end result was the DAT (R-DAT for consumer use). The development history of the DAT is very important to digital audio.

Research on the use of digital technology in recording and playing back audio signals began in the late 1960s, under Heitaro Nakajima at the NHK Technical Research Laboratories. This was around the same time as talk of FM broadcasts coming to the end of the experimental stage and starting in earnest. FM broadcasts were stereo capable, had acceptable sound quality and were very appealing to amateur music enthusiasts and audiophiles. However, there was still room for improvement, as the sound quality was not quite perfect. The question of how to improve the sound quality of FM broadcasts triggered the development of digital audio in Japan. Researchers started out first by reviewing the current situation: completely reconsidering and reassessing every element that went into FM broadcasting, from programmes to transmitters and receivers. The transmission itself as well as the master tape recorders used in the various parts of production, such as compiling and editing sound, clearly affected the overall performance. It was clear that improving the performance of these master tape recorders was of utmost importance to improve the quality of FM broadcasts. Fig. 14.1 shows the dynamic ranges at each stage from recording to transmitting. Magnetic recorders, enclosed by a dotted line, had the smallest dynamic range and therefore limited the overall performance of the entire system. Despite the fact that the master tape recorders of the day all used analogue recording, they were high-performance business machines and many of them were highly praised for their sound quality, even by famous recording studios. While various attempts were made to improve the performance of these master tape

recorders by improving the key components, such as the heads, or the hardware, such as the driving system, or varying the optimum recording levels, this achieved little in the way of improvements, which meant that nothing significant could really be expected to be achieved.

Having clarified the limitations of the existing analogue machines, it was necessary to somehow come up with a completely different solution. A proposal was made in the laboratory to try applying digital technology to audio. At the time, digital technology was being used in computers and communication technology. When researchers applied it to audio recording, they could see how it was theoretically possible for the expected performance to far outperform that of the existing analogue machines. However, while the idea of digital audio recording – storing the waveform of a signal as a numerical value – was relatively simple, implementing it in an actual machine was no simple matter. A vast amount of data had to be recorded in a far greater volume than for analogue recording; this had to be recorded and played back at very high speeds. The existing analogue tape recorders could not cope with such demands. To solve this issue, an idea was put forward to use a video tape recorder (VTR), which was being developed for business use at the time. VTRs were designed for recording video signals; they used rotary head technology to record a greater volume of signals at a higher speed than that of an audio tape recorder. The first audio prototype was completed in 1967, incorporating an A/D-D/A converter and a signal processing circuit into the VTR mechanism (Fig. 14.2). While the prototype was mono, the properties of the sound were sufficient to show the great potential of digital audio. The development team concentrated on further improvements to put it to practical use, completing a second prototype that was capable of stereo. In May 1969, a general-audience playback demonstration was held at a public event hosted by the NHK Technical Research Institute (now NHK Science & Technical Research Laboratories). The fresh sound and lack of noise stunned many industry stakeholders and general listeners in the audience. Incidentally, the demo music was an overture from the Rimsky-Korsakov opera *The Golden Cockerel*, performed by the NHK Symphony Orchestra, a fitting song choice to usher in the beginning of the digital audio era. The demonstration of digital audio to the public was a huge success, but there was no means of editing the sound. The devices were still in their early stage and would be difficult to downsize; they also had their own digital countermeasures for noise (largely because of inadequate error correction). The machines were not yet perfected enough to be of any

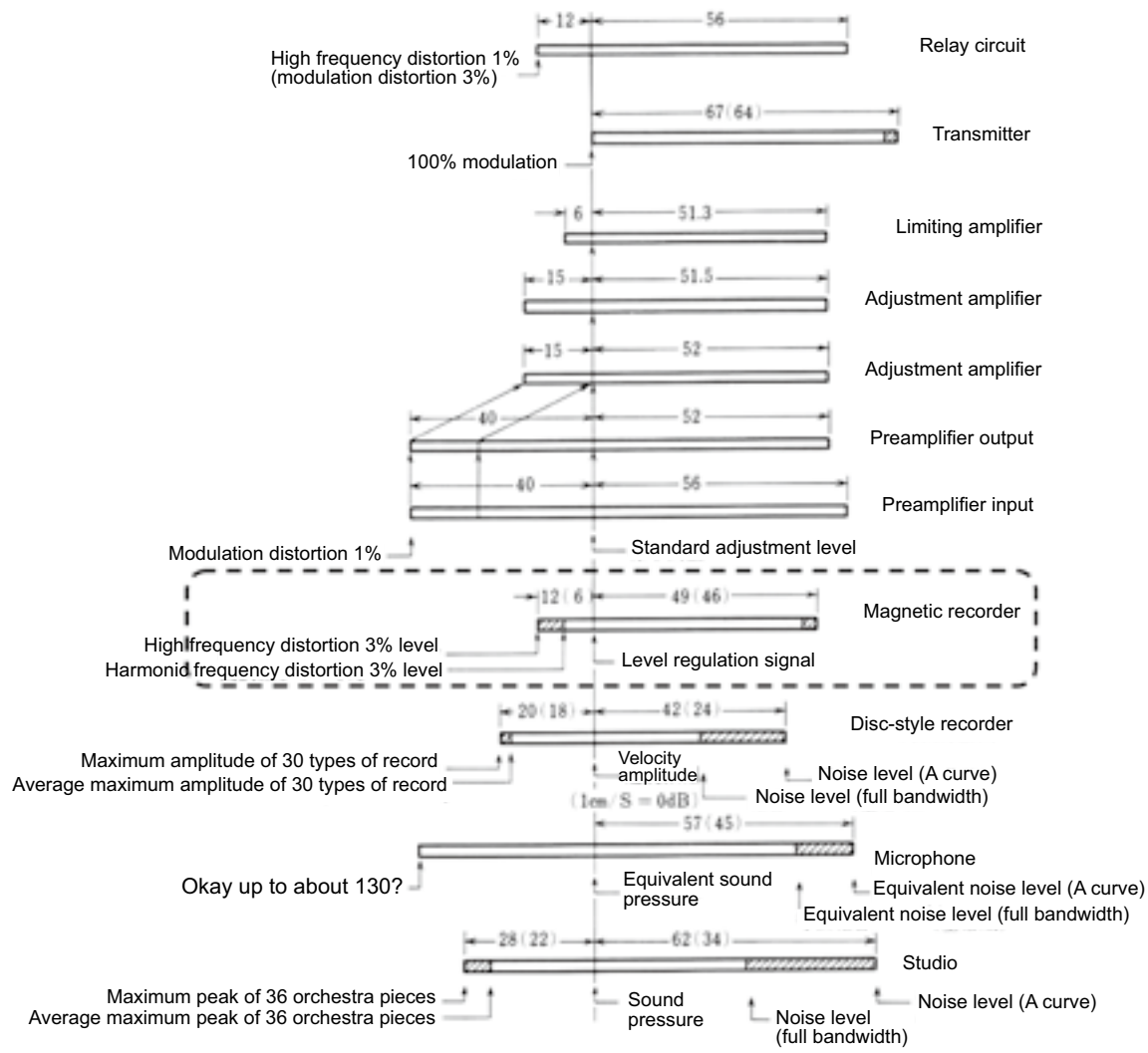

Fig. 14.1. Assumed dynamic ranges of the entire FM broadcasting system ⁽¹⁾

practical use as master tape recorders for broadcasting. The NHK put the development of digital audio recorders on hold for the time being, perhaps because it had deemed that it would take vast resources to address the issues in question. However, Nippon Columbia, which had worked on improving the sound quality of records by direct cutting, had a technical interest in digital audio and its potential. It took over the research and development of the technology and was able to create a master tape recorder with it. The machine used a so-called four-head VTR, with two-inch tape, as its recorder, complete with a 47.25kHz sampling frequency and 13-bit linear quantization. LP records that were mastered and produced on this digital master tape recorder went on sale in 1972 under the name of "PCM Records" (Fig. 14.3). The superior sound quality was highly regarded and became all the rage among audio enthusiasts.



Fig. 14.2. Digital audio recorder prototype 1 ⁽²⁾



Fig. 14.3. Japan's first PCM record (1972)
Recorded on a digital recorder independently developed by Nippon Columbia and used as a master record

14.2 Competition over the Development of Stationary-Head Machines for Business Use

Digital audio was unveiled for the first time in a public demonstration in 1969, taking major electrical manufacturers by surprise at its tremendous potential. Inspired by the development of the digital audio tape recorder (DAT), major electrical manufacturers hastened their development of master tape recorders for business use in the early 1970s. Production technology at recording studios and other music production sites became more sophisticated, with multi-track recording and more complex mixing processes. In turn, this required higher levels of sound quality with a greater dynamic range and higher S/N ratio than the existing analogue equipment. The audio genre began to make rapid progress as an industry; advanced recording and playback equipment became essential to audio device manufacturers for assessing and analysing their machines. Given these demands, fierce competition ensued to develop a DAT for business use. Several fairly-perfected systems were proposed right at the end of the 1970s (Table 14.1). Most of the systems proposed at this time were “stationary-head” machines, with open reel tape drive systems and heads with multiple recording tracks on them. These were very similar in appearance to the existing analogue master tape recorders. Although a number of major Japanese manufacturers, such as Sony, Mitsubishi, Hitachi and Matsushita, worked on developing this technology together with NHK, it was the BBC in the United Kingdom that developed and test-built a digital recorder with a stationary head like the ordinary analogue machines around 1972 (Fig. 14.4). The technology was taken over by US company 3M, which used it in a 32-channel machine using one-inch tape and a four-channel machine using half-inch tape. Production of these machines stopped after several years, due to their high

price and propensity to break down. In 1977, US company Soundstream remodelled the tape recorder, developing and announcing a four-channel DAT, but this, too, failed to gain a commercial footing and disappeared within a few years.

While DATs started out using VTR rotary head mechanisms, many stationary-head systems were developed because they were thought to be more beneficial for multi-track recording and editing. Both manufacturers and producers were rather conservative and felt uneasy with the rotary head mechanisms that had been developed for VTR and their ease of use; they already had certain underlying assumptions of what tape recorders should be like. Table 14.1 shows the stationary-head digital tape recorder systems for business use announced by each company. Compatibility required at least a minimum level of collaboration; accordingly, discussions were held at AES to define the Digital Audio Stationary Head (DASH) format in 1983. In 1985, the Professional Digital (PD) format was also proposed as a rival to DASH. Before long, fierce competition spread throughout the world of digital master tape recorders. Both systems had been independently developed by Japanese manufacturers, and it is no overstatement to say that the technology was completely Japanese and that Japan was leading the world in digital tape recorders for business use (Fig. 14.6). This accumulated technology and success with new audio equipment, such as the “headphone stereo”, the radio cassette player and the small-scale stereo, were major factors behind Japanese manufacturers leading the world in developing DATs for consumer use.



Fig. 14.4. BBC stationary-head DAT prototype (1972)⁽³⁾



Fig. 14.5. Sony 24-channel stationary-head DAT prototype (c. 1977)⁽⁴⁾



Fig. 14.6. Sony PCM-3324 DASH format 24-channel DAT⁽⁵⁾

Table 4.1. Comparison of Stationary-Head Prototypes for Business Use⁽⁶⁾

No.	1	2	3	4	5	6	7	8	9
Year announced	1972	1974	1975	1976	1977	1978	1978	1978	1978
Announced by	BBC	Sony	Hitachi	Mitsubishi	Sound stream	Matsushita	Sony	Mitsubishi	Toshiba
Tape width (inches)	1/2	2	1/2	1/4	1	1/4	1/4	1/4	1/4
No. of channels	2	2	2	2	4	2	2	2	2
No. of tracks (per channel)	8	28	6.5	4.5	6	30	3.5	4	16
Tape speed (cm/s)	38	76	38	38	76	38	38	38	38
Sampling frequency (kHz)	32	52	35.7	48	50	49.152	50	44.1	50
Quantisation (bit)	13	13	12	13	16	12.7 curve	12	15	14.7 curve
Modulation method	MFM	NRZ	MFM	MFM	MFM	Biφ	MFM	MFM	Biφ
Linear recording density (kbp)	4.4	1.73	5.55	12		3.3	17.9	17.64	3.3
Error control	2-bit parity	Double winding	Parity interpolation	CRC correction		2-bit parity Double winding	Adjacent code	CRCC adjacent code	1-bit parity Previous value hold

14.3 PCM Processor Concept

Many stationary-head DATs for business use were introduced as vital pieces of equipment to recording studios and other music production sites. The Sony DASH machines and Mitsubishi PD machines were competing for the market and quickly replaced the analogue master recorders and multi-channel tape recorders from the West that had dominated the field of business-use recorders. The following are the main reasons why Japan became a major power in the age of digitalisation.

- There were many parts manufacturers with precision machining technology able to develop and supply the high-precision, specialised components needed for building advanced tape running systems
- Superior head processing/assembling technology to incorporate multiple narrow track cores onto a single head (including thin films heads made with semiconductor manufacturing technology, etc.)
- Technology to develop and manufacture superior magnetic substance and tape suitable for digital recording
- Technology to develop and manufacture high-density, high-performance, dedicated semiconductors (signal processing, AD/DA converters, microprocessor control, servo LSI, etc.)
- Studies on the logical aspects of signal processing, such as error correction and modulation method, and rapid adaptation to hardware
- High precision general electronic components and mechanical parts

Tape recorders became increasingly digitalised throughout the world of business machines; by the mid-1980s, studios and broadcasters throughout the world had replaced their machines en masse. There were also growing opportunities for consumers to experience digital audio sound. While appreciation for digital audio steadily grew among music lovers, developing the technology for consumer use was considered too difficult. DATs for business use were far more expensive than the existing analogue machines, requiring far more parts. Being open-reel machines, they were also lagging behind other consumer-use machines in terms of their user-friendliness. There was no real expectation that they would ever become popular-use machines. Despite having developed stationary-head machines for business use and gained major footholds in the business market with their DASH and PD formats, even Sony and Matsushita struggled to develop a machine for consumer use.

At the same time, VTR for home use was entering its final stage of development. “Betamax” was announced and released in 1975, followed by “VHS” the following year in 1976. Home-use VTR made its debut with high hopes of

making it big. Machines capable of recording 1-2 hour TV programmes entered the market at affordable prices. These were superior products with much thought put into their user-friendliness, such as having a relatively small cartridge size with half-inch tape. Admittedly, earlier VTR cartridges had been seen, in the form of the “U-matic” cartridge in 1971. At $\frac{3}{4}$ -inch, the tape in these machines was wider than in the Betamax and VHS machines. This meant that the cartridges and machines were larger and more expensive, so they did not become popular for home use. Nevertheless, they began to be used by businesses such as broadcasters and came to play a leading role in Electronic News Gathering (ENG).

The team at Sony’s research and technology division began to wonder whether a digital audio recorder could be made using a household VTR as a recorder. The first DAT trialled by the NHK was a business-use VTR; while it was not the usual use for the VTR mechanism, with a little effort the VTR itself could be made to record a digital signal. While the price of household VTRs was expected to eventually go down, the necessary alterations to make them into dedicated DATs meant that there would probably be no cost benefits to mass production. Development promptly began on a standalone digital audio circuit, with the idea that if such a machine could be simply used as a recorder without touching the VTR technology, the result would be a household DAT that was affordable to general users. Since the purpose of VTRs was to record television signals, they had horizontal and vertical blanking intervals; this meant that they were in principle not really suited to recording continuous signals such as audio signals. Digital audio involves treating an audio signal as data, meaning that compression/expansion occurs relatively freely on the time axis. In practice, however, it was more difficult than expected due to digital data processing taking up a lot of memory and costing more than anticipated. Furthermore, the idea of error correction had not been thought through. Dropout (signal loss) on a VTR has no major effect on the picture, but it produces a catastrophic amount of noise. However, although the latest digital technology was still lacking in many areas, Sony released the consumer-use PCM processor in 1977, which worked directly connected to a VTR, kicking off the popularisation of digital audio machines for general users (Fig. 14.7).



Fig. 14.7. The world's first PCM processor, Sony PCM-1 (¥480,000) (1977) ⁽⁷⁾

14.4 Creation of Consumer-Use DATs

Digital recording had been limited to the world of business, but the advent of the PCM processor meant that it could now be enjoyed in the home as well. As general users came into increasingly more frequent contact with digital audio with this machine, its sound quality began to receive more attention in publications such as audio magazines. This earned recognition of digital audio as something with appeal and potential, and raised expectations regarding it. Around the same time, the audio world was ablaze with news of developments and format disputes in relation to digital audio discs, which later led to the Compact Disc. As expectations regarding digital audio grew, naturally, so did the idea to digitalise the Compact Cassette, the leading magnetic recording system for consumers. In fact, as the CD was being developed, audio companies were researching digital tape recorders for consumer use; however, by the early 1980s, none of them had made it any further than the laboratory stage. Even amidst this race to develop a digital tape recorder for consumer use, competition was raging between the stationary-head (S-DAT) format, which focused on the audio aspect, and the rotating-head (R-DAT) format, which aimed to improve on the existing VTR technology (Figs. 14.8, 14.9).

The CD – a digital version of the existing analogue records – entered the market in 1982 and immediately took hold as a music storage medium. CDs and CD players were a system with overall appeal that not only offered good sound quality, but also a novel shape, superior digital operability using TOC data and the convenience of random access. The successful introduction of the CD intensified the race to develop digital recorders for consumer use. The term “DAT (Digital Audio Tape-recorder)” seems to have taken hold around this time to refer to digital audio tape recorders for consumer use.

Developers thought up ideas to combine the far superior sound quality of digital audio with an extra recording area for additional information, called sub-code, to vastly improve the

user-friendliness of the DAT. This led to the proposal of new, highly-advanced, highly-desirable specifications. In terms of performance, the DAT outdid the CD with a sampling frequency of 48kHz and 16bit quantisation. It also offered two hours of continuous recording on a cartridge smaller than the Compact Cassette – it truly was a dream machine. However, companies worked on it separately, meaning a large number of incompatible formats, which prevented it from becoming popular. A major factor to the success of the Compact Cassette was maintaining strict compatibility; all companies involved understood the importance of having unified standards. Accordingly, the industry organised a “DAT Discussion Panel” in 1983 to work on unifying standards. A comparison was made between the R-DAT and S-DAT formats and uniform standards were formulated for both formats. Around two years later, in 1985, technical specifications were issued (Tables 14.2, 14.3) for S-DAT and R-DAT, based on the results of various investigations and experiments. Having compared the two formats, a comment was passed acknowledging the advantage of R-DAT in terms of short-term implementation. Consequently, R-DAT was first commercialised as a DAT for consumer use (Figs. 14.10, 14.11). The following section discusses the development of each DAT format for consumer use.

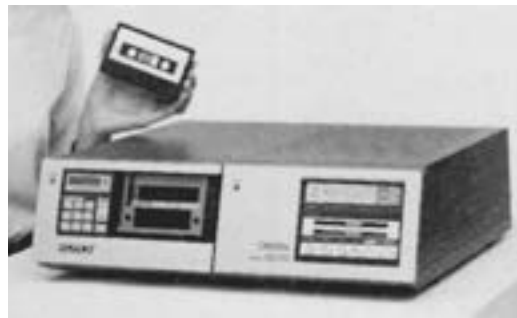

Fig. 14.8. Sony S-DAT prototype (1981) ⁽⁸⁾



Fig. 14.9. Sony R-DAT prototype (1982) ⁽⁹⁾

Table 14.2. Main S-DAT Specifications ⁽¹⁰⁾

Mode	Recording/Playback Mode				Pre-recorded
	Standard	Option 1	Option 2	Option 3	
(1) No. of channels	2	2	2	2 x 2	2
(2) Sampling frequency (kHz)	48	32	32	32	44.1
(3) Quantisation (bit)	16	16	12	12	16
(4) No. of data tracks	20	20	20	10 x 2	20
(5) Tape speed (cm/s)	4.76	3.17	2.38	4.76	4.37
(6) Transfer rate (MBPS)	2.4	1.6	1.2	1.2x2	2.205
(7) Linear recording density (kBPI)	64	←	←	←	←
(8) Error correction code	double Reed-Solomon code C2: (29, 27, 3) C1: (40, 32, 9)				
(9) Modulation method	8-10R				
(10) Redundancy (%)	36	←	←	←	←
(11) Sub-code rate (kBPS)	128	85.3	64	64x2	117.6
(12) ID code rate (kBTS)	10	6.66	5	5x2	9.19
(13) Cassette dimensions (mm)	86x55.5x9.5				
(14) Maximum recording time (minutes) (tape thickness 10µm)	90	135	180	90	98

Table 14.3. Main R-DAT Specifications ⁽¹¹⁾

Mode	Recording/Playback Mode				Dedicated Playback Mode	
	Standard (48k mode)	Option 1 (32k mode)	Option 2 (32k-4 CH mode)	Option 3 (32k-4 CH mode)	Normal Track (44k mode)	Wide track (44k-WT mode)
No. of channels (CH)	2	2	2	4	2	2
Sampling frequency (kHz)	48	32	32	32	44.1	
Quantisation (bit)	16 (linear)	16 (linear)	12 (non-linear)	12 (non-linear)	16 (linear)	16 (linear)
Linear recording density (kbpI)	61	61			61	61.1
Areal recording density (MbpI ²)	114	114			114	76
Transfer rate (Mbps)	2.46	2.46	1.23	2.46	2.46	
Sub-code capacity (kbps)	273.1	273.1	136.5	273.1	273.1	
Modulation method	8-10 modulation method					
Correction method	double Reed-Solomon code					
Tracking method	Area split ATF					
Cassette size (mm)	73x54x10.5					
Recording time (minutes)	120	120	240	120	120	80
Tape width (mm)	3.81					
Tape type	Metal powder					Oxide tape
Tape thickness (µ)	13±1µ					
Tape speed (mm/s)	8.15	8.15	4.075	8.15	8.15	12.225
Track pitch (µ)	13.591				13.591	20.41
Track angle	6° 22'59.5"					6° 23'29.4"
Standard drum specifications	φ30, contact angle 90°					
Drum rotation speed (r.p.m.)	2000		1000	2000	2000	
Relative speed (m/s)	3.133		1.567	3.133	3.133	3.129
Head azimuth angle	±20°					
Notes	Always equipped with standard recording mode	Option for PCM broadcast recording	Half-speed option for long recordings	4ch option	Always equipped with dedicated music tape mode Playback only; cannot record	Always equipped with dedicated music tape mode Playback only; suitable for contact printing



Fig. 14.10. Sony DTC-1000ES, the first R-DAT machine (1987)



Fig. 14.11. Portable R-DAT Sony TCD-D3

14.5 Format Competition in Developing DATs for Consumer Use

Confident in its accumulation of tape recorder technology, Sony's research and technology division set about researching and developing a consumer-use DAT in earnest in the late 1970s. At the time, the question of what technology could be used to achieve a consumer-use DAT was a topic of heated debate among audio engineers. There was no obvious answer, which in itself often led to sharply opposing views among engineers. There were several opposing groups of engineers at Sony, each advocating its own opinion. The path Sony took was to have these groups develop three separate formats concurrently.

14.5.1 Stationary Heads

This was the archetype for the S-DAT format, based on the same tape running system as the existing cassettes. This head could record multiple tracks at once, meaning it was capable of handling the necessary volume of data. The main aim of this development was to produce an ultra-precise recording/playback head capable of recording around 20 tracks per side with a 3.8mm tape like the Compact Cassette. To read an accurate signal from the countless number of narrow tracks, the playback head used the magnetoresistance (MR) effect. Developers worked on an MR head that could read the changes in magnetism on the tape as changes in resistance in the MR element. Both the playback head and recording head utilised a new innovation called the "thin film head", made with semiconductor processing technology. This manufacturing process was later used to create multichannel DAT heads for business use. Fig. 14.12. shows the S-DAT track pattern.

Philips later developed the S-DAT idea into the Digital Compact Cassette (DCC) system. Since the S-DAT system had 20 tracks for the main audio data, it required a very precise tape running system and advanced signal processing. The DCC system had less than half the number of tracks, allowing the heads and the overall system to be simplified. Any performance limitations due to the reduced

recording density could be compensated for with "data compression technology". This was a second-generation DAT with sound quality rivalling that of the CD. The cassettes were also compatible with the Compact Cassette system and there was a standard in place to ensure that a DCC machine could record and play DCCs as well as play Compact Cassettes. However, the DCC lost out to the MD and disappeared off the market within a short space of time (Fig. 14.13).

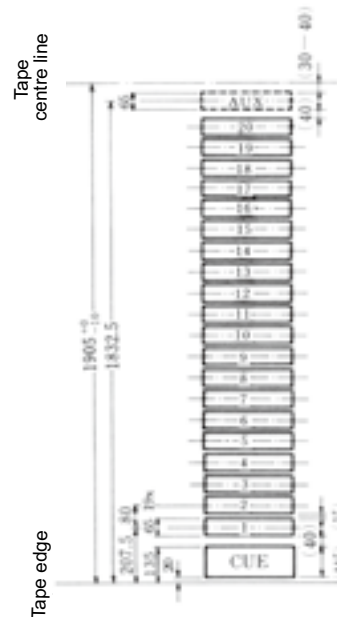

Fig. 14.12. S-DAT track pattern⁽¹²⁾

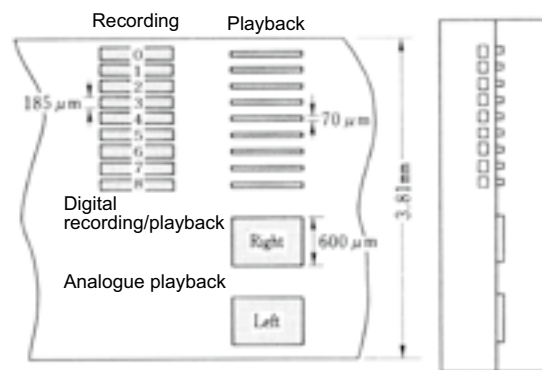

Fig. 14.13. DCC track pattern⁽¹³⁾

14.5.2 Rotary Heads

The so-called R-DAT format was used by a minority of companies in the industry who hoped to produce a consumer-use DAT with this format. The key part in the rotary head system was the rotary drum, which included the heads. This required redeveloping the entire system from scratch. It was a major hurdle for manufacturers to develop a dedicated

mechanism when they had only ever built the existing style of tape recorders and had never worked with a helical scan tape drive system. Generally, it takes time to develop a new mechanism, building up experience and testing prototypes. There was much more involved in this development than for the stationary head, which only required remodelling existing parts to make them smaller and concentrating on producing a multi-channel head. Sony was working on an 8mm video around the same time and pushed forward with DAT development in this format. It was fairly straightforward for the audio engineers to learn and use the unfamiliar rotary head technology, such as the various components and the tape drive technology. The developers worked on a dedicated audio mechanism using VTR rotary head technology, taking care to simplify and downsize it to make it more appealing (Fig. 14.14). By making maximum use of existing technology, they were able to keep the development reliable and rational. The R-DAT system became a significant piece of recording equipment in its day. It had good functionality and performance and reached an adequate level of completeness as a consumer product quite early on, becoming recognised as the first DAT for consumer use. It was made into a series of products: decks, portable machines and professional equipment, and was sold all over the world.

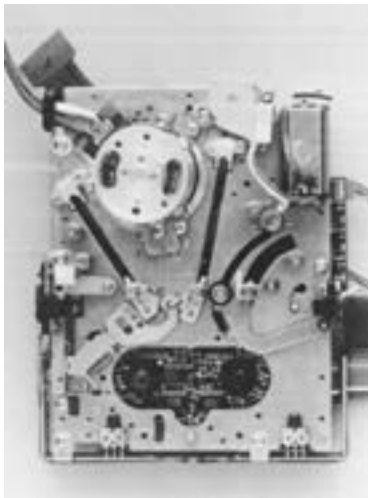

Fig. 14.14. R-DAT mechanism
 Drum diameter: 30mm
 Winding angle: 90°
 No. of heads: 2
 No. of motors: 4

14.5.3 NT Format

The stationary-head S-DAT prototype (Fig.14.8) was announced in 1981, followed by the rotary-head R-DAT prototype (Fig. 14.9) in 1982. These formats continued to develop and were put up for examination at the “DAT Discussion Panel” with the aim of standardisation. While these developments in the digitalisation of the Compact Cassette continued, Sony’s research and technology division

was working on another DAT format. The aim of this design was not just the minimum necessary development to improve sound quality through digitalisation, but rather to create an ambitious new product that used digitalisation technology to its maximum potential to achieve a level of miniaturisation thought impossible in a tape recorder, thus creating new value in the product. The product was the NT system, with a sampling frequency of 32kHz and 12-bit quantisation, capable of two hours of digital recording on an ultra-small cassette the size of a postage stamp. It was launched in 1992 as the “NT-1”. Housed in a tiny casing and powered by a single AA battery, the device was packed with a mechanism as small and precise as a watch as well as a circuit for every function from recording to playback to digital signal processing. The small size of the specially-developed tape was astounding; it even appeared in the 1994 Guinness Book of World Records as “the world’s smallest mass-produced tape” (Fig. 14.15).

The mechanism developed for this machine made full use of the distinct nature of digital data with a non-tracking rotary head system that traced the signal-recorded area (track) multiple times, reading only the necessary information without fully tracing the entire track. The mechanism then re-aligned this digital data along the time axis, producing the correct signal. The product name “NT” was an acronym for “Non-Tracking”. The ultra-small cassette itself had a number of clever ideas incorporated into it. The device also had a non-loading mechanism, whereby the drum on which the rotary heads were mounted was inserted into the cassette. The mechanism had to be miniaturised to achieve this (Fig. 14.16). With low electricity consumption in its electronic circuits as one of its goals, it offered astounding performance by running on a single AA battery. While this was a very technically ambitious development that fully incorporated digital technology and mechatronics, it did not succeed as a business venture. This was perhaps because the greater the detail, the more time it took to develop. It was released in 1992, the same year as the MiniDisc (MD); this was the era of second-generation digital recording systems using digital compression technology. The MD made full use of this compression technology and showed great promise for the future. This provided a good opportunity to get a number of interested parties thinking about the possibilities in switching to semiconductor memory recording media, which was still quite expensive at the time.



Fig. 14.15. Sony NT-1 and exclusive tape (1992)⁽¹⁴⁾

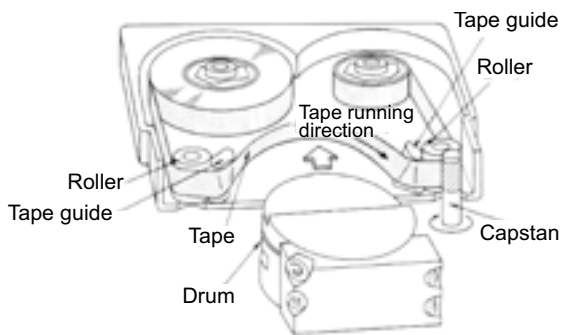

Fig. 14.16. Non-loading mechanism⁽¹⁵⁾

14.6 Copyright Issues

Given its overwhelming recording and playback capabilities, the appearance of the consumer-use DAT was an epoch-making event in tape recorder history. The nature of digital recording meant that the content would not become corrupted through copying, which sparked a debate over so-called digital copyright issues. In 1987, CD shipments were outselling analogue records; CDs had become a major revenue source for the record industry. The appearance of the DAT, which could record CDs without losing any sound quality, inevitably presented a major threat to those with financial interests in the music content. Although tape recorders had typically been used up until that time to copy records onto Compact Cassette and listen to them on “headphone stereos” or car stereos, the established interpretation of music copyright in Japan allowed private recordings to be made for use within the household. A decision by the Supreme Court of the United States in the so-called “Betamax case” in 1984 held that home use of a VTR does not constitute copyright infringement. Rather than permitting copying, the decision interprets that it is lawful for consumers to use a VTR as technology that offers

a time-shift function. Music/video copyright holders were becoming increasingly nervous about the growing spread of machines capable of making copies. Hardware developers for consumer-use DATs had given this matter some consideration; the first machine released had its specifications set in such a way that it could not digitally record at 44.1kHz, the sampling frequency of CDs. However, this created a discord between those creating the content and those creating the hardware. It was difficult to dispel users’ doubts and misgivings, thus tripping the DAT up in its initial sprint. The hardware and content factions entered into a number of negotiations over what was arguably the world’s first digital copyright issue; by 1990 they had reached an agreement. The two essentials of the agreement were as follows.

- (1) Serial Copy Management System (SCMS) technology that restricts copying shall be used when making digital copies, preventing unlimited copies being made.
- (2) Each country shall develop legislation to apply a private copying levy system to digital recording equipment and media (such as tape).

Rather than determining whether a single copy was prohibited/permitted, the SCMS prohibited/permitted copies according to the source of the recording. The system determined whether or not a digital copy was prohibited/permitted according to what the original source of a digital copy was. This meant that first-generation protected works (such as CDs) could be copied, but following generations could not be copied. The goal of this was to prevent a flood of “copied works of the same quality as the original”, which was one of the advantages of digital recording. This was a compromise to uphold consumers’ right to private copying as well as alleviate the threat digital copying posed to copyright holders. Combining this system with a private copying levy system resulted in agreement over the first digital copyright issue in history.

Around the time that CDs were announced, Sony and Philips came up with a unified standard for transferring data between digital audio machines. This was called the Sony Philips Digital Interface (SP-DIF) and was used in business machines. After CDs hit the market, the standard was developed into the international standard IEC958 (now IEC60958) for consumer use. Specific SCMS information was transmitted along with audio data according to standard IEC958; this additional information included information pertaining to the generation of the content (music) being played. The information also determined the source machine and the destination machine and distinguished what kind of machine the digital data came from. This information determined the behaviour of the recorder receiving the digital data. Tape recorders could of course record non-copyrighted works. Material recorded privately by users with no copyright claims to it could be freely digitally transferred

and copied on SCMS machines. This agreement allowed digital copying from first-generation CDs only. In 1990, the DAT re-emerged as an SCMS-compatible device and was welcomed as the ultimate tape recorder by audiophiles, semi-professionals and even fully-fledged professionals. Later, second-generation digital recorders for MD, DCC and other media, aimed at a wider range of users, also started using this system that had been established for the DAT. The transition to SCMS was relatively smooth and a definite market for these recorders developed within a short space of time.

The digital copyright debate started with the emergence of the DAT. The debate continued as computer technology and digital video technology (DVD, BD) advanced, with the protection and use of digital content becoming a major topic of concern.

References

- 1) Mori, Yoshihisa, et. al. Onkyō-Gijutsu-Shi [History of Sound Recording], Tokyo University of the Arts Press, March 2011, p. 143.
- 2) Ibid., p. 144.
- 3) Ibid., p. 145.
- 4) Onkyō-Gijutsu-Shi, p. 145.
- 5), 7) 14) Provided by Sony Corporation.
- 6) Onkyō-Gijutsu-Shi, p. 146.
- 8), 9) Ibid., p. 148.
- 10) Ibid., p. 149.
- 11) Ibid., p. 150.
- 12) Ibid., p. 152.
- 13) Ibid., p. 153.
- 15) Ibid., p. 154.

15 | Conclusion

The most common style in which people listen to music today is of listening to music stored in a semiconductor memory on a small-scale, portable device through headphones. Small-scale, battery-operated devices enable people to listen to music while on the move, at a destination point, or individually at home through headphones. Making music personally accessible anytime, anywhere is quite a recent achievement that only became possible around 30 years ago with the appearance of the portable “headphone stereo”. The “Walkman” at that time was a dedicated playback tape player that used the very successful Compact Cassette format. This historic product revolutionised the style in which people listened to music and took hold with a culture of its own.

Music listening developed as a means of household entertainment as technology developed in the 20th century. Related equipment and service industries were also very successful. It was not all that long after sound was first recorded on Edison’s phonograph that listening to music recordings on disc-style records became a popular style of enjoying music at home. As the record industry rose to the forefront of the times, there was a flurry of development to try to improve the sound quality of recording and playback machines. As electrical technology advanced, research continued on the disc-style records to improve their sound quality and lengthen their playing time. This work reached completion in the late 1950s with the stereo LP record, which then came to play a long leading role in home audio.

The theory behind the gramophone (record) was that of recording sound on mechanically etched grooves in the medium. The idea of “magnetic recording”, wherein sound changes are captured as electrical changes and recorded as changes in induced magnetism, had been proposed and the steel wire magnetic recorder invented at the end of the 19th century. Magnetic recording developed in the form of the tape recorder in Germany prior to the Second World War. Following the war, the United States and other countries worked tirelessly on technology development, resulting in a superior recording machine, as discussed in Chapters 3 and 4 of this report. Research on magnetic recording was carried out in Japan quite early on as well, with results rivalling those of other countries, such as the discovery of AC bias and the development of new magnetic substances. Undoubtedly, this research and the accumulation of technology laid the foundation for developing the domestically-produced tape recorder into a major post-war industry. The Compact Cassette appeared in the mid-1960s and started on its journey towards becoming the de facto standard. The Compact Cassette performed poorly alongside the open-reel machines of the time and was thought to be

unsuitable for music recording, one of the main purposes for recorders. Various Japanese manufacturers worked hard to solve this issue, developing new magnetic substances for the tape, new head materials, more precise mechanism designs, smaller motors for sound applications and improved technology for rotation control. These developments culminated in the cassette deck, proving that the Compact Cassette could perform satisfactorily as a music recorder and boosting the confidence of users and manufacturers alike in the potential of the Compact Cassette. While adhering to standards that emphasised compatibility in some respects prevented any short-lived innovations, working on precise developments in limited conditions to achieve superior function and performance perhaps suited the Japanese style of product development. Japanese manufacturers, brimming with confidence at having made major contributions to the development of the Compact Cassette, were competent enough to draft new standards and even formulated their own standards for the Microcassette and Elcaset in the 1970s.

Japanese-made music equipment had its beginnings in the transistor radio. By the early 1970s, it had become a major export industry, with Japan sending out audio equipment far and wide on the global market. Manufacturers of mechanical and electrical components for the Compact Cassette tape recorder developed their technical capabilities, which boosted the potential for the product. The pace of product planning and development quickened, aimed at expanding the range of possible uses for the tape recorder by making it smaller and lighter. As the idea of portable audio made possible by a smaller and lighter product began to take hold, the development of integrated products such as the radio cassette player enabled users to build up their music collections on Compact Cassette. It was in these circumstances that the Walkman was created: a product designed to enable people to “listen to music, anytime, anywhere”. Although the Walkman was a type of tape recorder, the essential point was the concept of “listening to music, anytime, anywhere”. Other products using other media, such as CDs or MDs, were also developed along the same concept and continued to be popular. According to a report by Sony, it had shipped out a cumulative total of 220 million personal tape players and 120 million personal CD players by 2009.

By expanding the range of uses for Compact Cassette machines, Japan began to lead the world in tape recorder technology and products. As the age of digitalisation approached, Japan was in a position to spearhead the development of technology and determining of policies. While digital audio technology, with its ground-breaking sound quality capabilities, radically altered the face of

audio products, it was tape recorders that paved the way for digitalisation. Business-use tape recorders improved dramatically in performance; these were used for recording high-quality master copies of music content. This contributed greatly to the creation and development of the CD. Chapter 14 recounts the history of development of the Digital Audio Tape-recorder (DAT). The consumer-use DAT was the ultimate tape recorder system, achieving a level of performance that had not been possible in the analogue era on a cartridge smaller than the Compact Cassette. This was the result of a winning combination between Japan's precise mechatronics and semiconductor technology and its ability to develop basic components, such as tape heads – a skill learned and refined during the competitive development of Compact Cassette machines. Digital audio afforded a greater degree of freedom in signal processing than analogue. The compression process meant a reduced volume of media; it was also possible to transfer music data without the use of storage media. The beginning of the chapter mentions that the modern style of listening to music came about through the development of digital technology. While the role of the tape recorder has been taken over by recording devices with hard disks or semiconductor memory, in terms of the way in which music is appreciated, there has been no change in the basic concept embodied in the Walkman. Just as the Compact Cassette “headphone stereo” revolutionised the way in which people listened to music, the hope is that Japan's development and product planning capabilities will transform digital audio with a new breakthrough that will offer users unexpected, new experiences and enjoyment.

Acknowledgements

The author received invaluable materials and information from many sources when preparing this “Systematic Examination of Tape Recorder Technology” report. The author is very grateful for having been able to ask contributors for more detailed descriptions and accounts and expresses his heartfelt gratitude to the following people in particular.

Yoshiharu Abe, formerly of TEAC Corporation

Masahiro Fujimoto, formerly of JVC

Mitsuru Kashiwabara and Sadaharu Igeta, of Sony Corporation

Satoshi Kageyama and Noriaki Furuta, formerly of Panasonic Corporation

Masanori Harui, of Panasonic Corporation

Masami Murayama, of Nissei Technology Corporation

Satoshi Shitara and Reiko Kinoshita, of JEITA

Ryoji Menjo and Yoshihisa Mori, of the Japan Audio Society

Cited Works

* Other than the literature cited in the “References” section at the end of each chapter.

- 1) Nakagawa, Yakuzō. Dokyumento Nihon no Jiki Kiroku Kaihatsu [Documented Japanese Developments in Magnetic Recording], Diamond, 26 January 1984.
- 2) Nakajima, Heitarō and Odaka, Kentarō. Zukai DAT Dokuhon [Illustrated DAT Reader], 25 July 1988.
- 3) Sekai no Ōdio: Tekunikusu [World Audio: Technics], Stereo Sound Publishing, 20 May 1978.
- 4) Sekai no Ōdio: Sonī [World Audio: Sony], Stereo Sound Publishing, 31 October 1978.
- 5) Yashima, Kōki. Sony Chronicle 2010, Sony Magazines, 10 March 2010.
- 6) Sony ES Review© Rinji Zōkan-gō (ES Review Sonī Sōritsu 35 Shūnenkinen-gō) Audio 35 Years [Sony ES Review © Special Issue (35 Year Anniversary Issue) Audio 35 Years], Sony Corporation.

Tape Recorder Flow Chart

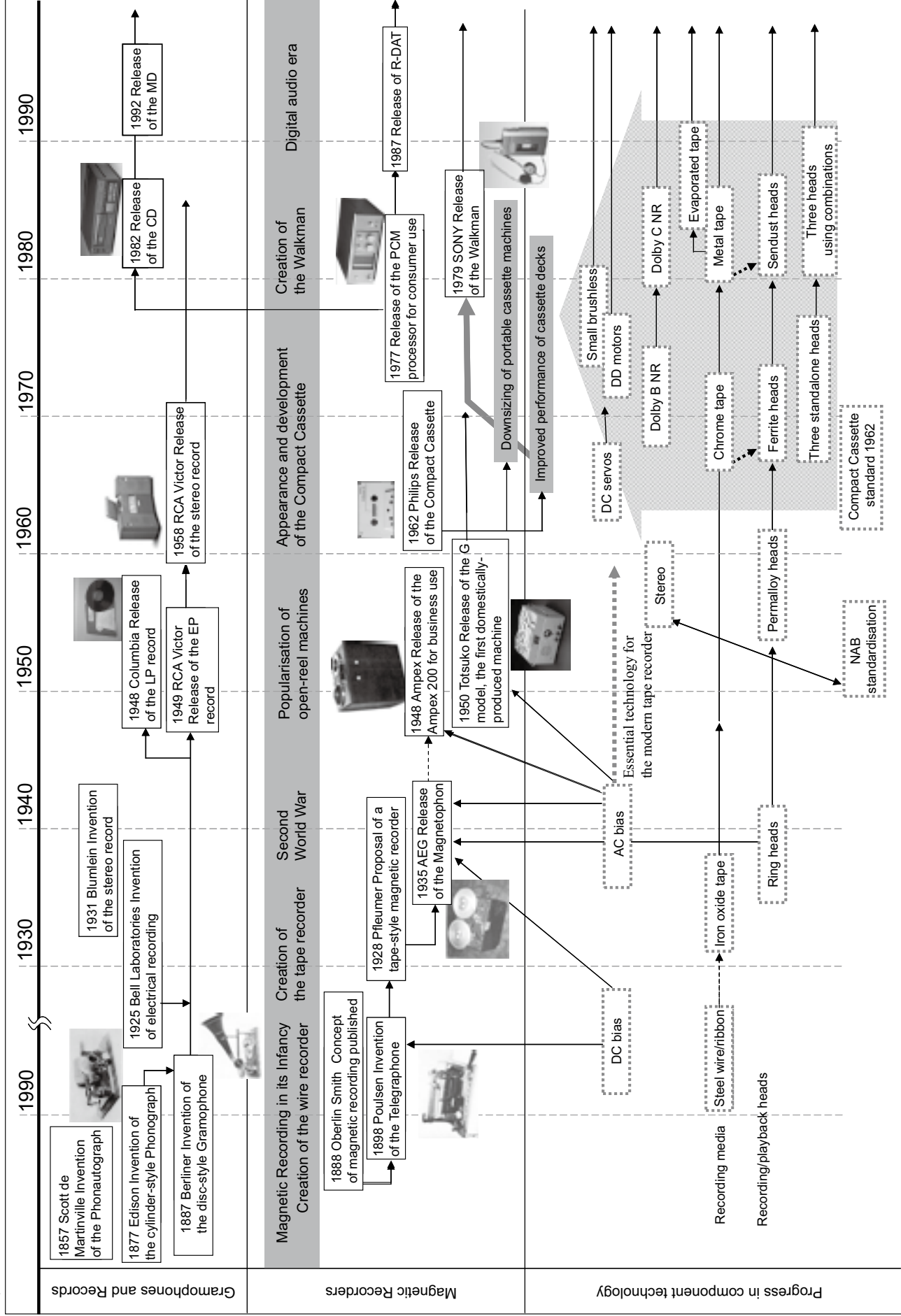

Timeline

Year	Event related tape recorders	Event related to recording/broadcasting
1857		Scott de Martinville invents the "Phonautograph", the world's first sound recorder
1877		Thomas Edison invents the "Phonograph", the world's first cylinder-style recorder
1887		Emil Berliner invents the "Gramophone", a disc-style recorder
1888	Oberlin Smith publishes the idea of magnetic recording	
1898	Valdemar Poulsen invents the "Telegraphone", the world's first magnetic recorder	
1902	Poulsen and Pedersen apply for a patent for DC bias	
1920		Commercial radio broadcasts begin in the United States
1921	Carlson and Carpenter apply for a (US) patent for AC bias	
1925		Radio broadcasts begin in Japan
1928	Fritz Pfeleumer completes the "Sound Paper Machine", a tape-style recorder	
1934	AEG completes the "Magnetophon"	
1938	Nagai, Igarashi and Ishikawa apply for the "Nagai Patent", a (Japanese) patent for AC bias	
1939	Wooldridge applies for a (US) patent for AC bias	
1940	Weber and von Braunmühl apply for a (German) patent for AC bias	
1941	Camras applies for the "Camras Patent", a (US) patent for AC bias	
1948	Ampex releases the Ampex 200	Columbia announces LP records
1950	Totsuko releases the G model, Japan's first domestically-produced tape recorder	
1951	Totsuko completes the M-1, a portable tape recorder	
1958	RCA Victor releases the RCA Cartridge system	RCA Victor releases the 45/45 stereo record
1962	Philips test-releases the Compact Cassette	
1963	Grundig, Telefunken and Blaupunkt release the DC International format	
1965	Philips EL-3301 becomes the first Compact Cassette machine to be released in Japan	
1969		Proper FM broadcasting begins in Japan
1970	BASF releases chrome tape	
1970	Matsushita releases the RS-275U, the first direct-drive cassette deck	
1971	TEAC releases the A-350, the first cassette deck with inbuilt Dolby NR	
1973	Nakamichi releases the Nakamichi 1000, a three-head cassette deck	
1973	Sony releases double-coated DUAD tape	
1973	Sony releases the TC-2850D "Cassette Densuke"	
1975		Consumer-use VTR "Betamax" appears
1976		Consumer-use VTR "VHS" appears
1977	Sony releases the PCM-1, the world's first consumer-use PCM processor	
1978	3M releases Metafine metal tape	
1978	Matsushita releases Ångrom evaporated tape for microcassette	
1979	Sony releases the TPS-L2, the first Walkman	
1982		Compact Discs (CDs) appear
1983	Cassette-case-sized Walkman WM-20 released	
1987	Consumer-use DATs appear	
1992		MiniDiscs (MDs) appear

Tape Recorders
List of Registered Devices

No.	Name	Year manufactured	Location	Resource Status	Reason for Selection
1	TPS-L2, the first Walkman	1979	Sony Archives	On display	The world's first "headphone stereo". The combination of a dedicated playback tape recorder and lightweight headphones drastically changed the way in which people all over the world listened to music; the good sound quality and the concept of listening to music anytime, anywhere was especially appealing to young people. The pet name "Walkman" was even accepted into the Oxford English Dictionary.
2	G model open-reel tape recorder	1950	Sony Archives	On display	Japan's first domestically-produced open-reel tape recorder for home use. There were two types: the A type, with a limiter (limiting amplifier) and the B type, without a limiter. The tape was developed at the same time and consisted of iron oxide on a paper base.
3	SP-10, the world's first direct-drive turntable	1970	Panasonic Museum	On display	The world's first record turntable system to have a DC direct-drive motor developed and incorporated into it. It incorporated control technology for slow rotation speeds and became the basis for direct drives in other AV equipment.
4	TC-50, a handheld Compact Cassette recorder	1968	Sony Archives	On display	A small-scale tape recorder with an inbuilt microphone capable of being operated with one hand. This model maximised the small size of the Compact Cassette and was used by the crew aboard the Apollo 10 spaceship.
5	RQ-303 MySonic, a small-scale, battery-operated, open-reel tape recorder	1963	Panasonic Museum	On display	A small, battery-operated tape recorder for home use, with a dedicated reel called the No. 4 and a tape speed of 4.8cm/s. Its piano-key buttons made it very easy to use. It went on sale at a price of ¥10,000 at a time when popular-model, home-use machines were being sold for around ¥20,000. It became very popular and took a large share of the market.
6	PCM-1, the world's first PCM processor for consumer use	1977	Sony Archives	On display	An audio unit enabling PCM digital recording and playback at home in connection with home-use VTRs in the Betamax and U-matic formats. The harbinger of digital audio, giving consumer machines an ultra-high quality of sound that would have been difficult to achieve with analogue technology. Priced at ¥480,000.
7	"Cassette Densuke" TC-2850SD, a portable stereo recorder	1973	Sony Archives	On display	A battery-operated, portable stereo tape recorder capable of recording in stereo. Used Dolby NR and other features to achieve a level of sound quality rivaling that of ordinary tape decks. A popular model with an inbuilt microphone amplifier, playing a major role in starting the "live recording boom". Priced at ¥52,800.
8	RS-275U, the world's first Compact Cassette deck with a direct-drive motor	1970	Panasonic Company History Office	In storage	The world's first high-level cassette deck with a direct-drive capstan motor. Improved tape feed precision improved factors such as wow and flutter; this contributed to the improved performance of later Compact Cassette machines.
9	RS-1500U, a zero-loop, open-reel tape recorder	1976	Panasonic Company History Office	In storage	A high-grade open-reel tape deck that achieved stabilised tape running performance with a zero-loop tape running system. Equipped with a DC direct-drive system on the capstan developed for turntables.

National Museum of Nature and Science
Systematic Examination of Technology Report, Volume 17

20 August 2012

- Editor: National Museum of Nature and Science (Independent Administrative Institution)
Center of the History of Japanese Industrial Technology
(Under charge of: coordinating editor: Takayuki Nagata; editor: Toshihiko Okura)
English version: Osamu Kamei
- Publisher: National Museum of Nature and Science (Independent Administrative Institution)
7-20 Ueno Park, Taito-ku, Tokyo 110-8718
Tel: 03-3822-0111
- Printer: (Japanese version) Shinkousoku Printing, Inc.
Translation and English version: WIP Japan Corp.

